



FMIR WINDOW

○ GENERAL CHARACTERISTICS :

- Interface window for equipment of infrared thermography measurement
- Temperature of use : 10 à 200°C
- Pressure behaviour : 1 to 5 bars maxi according to the crystal used
- For use from 0.3 to 14 μm according to the crystal used
- Two choices of frame :
 - Treated Aluminium black SAO
 - Inox

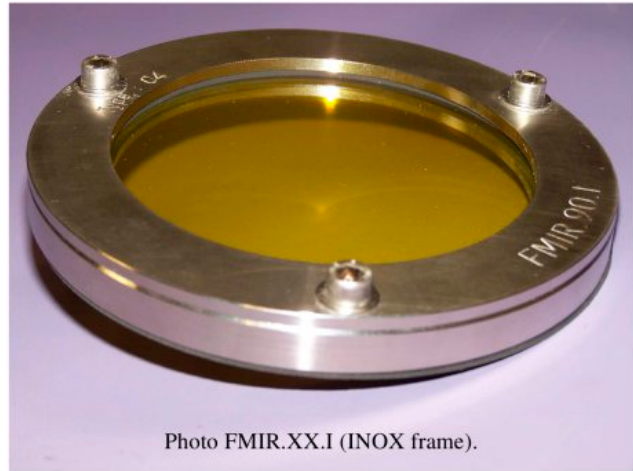
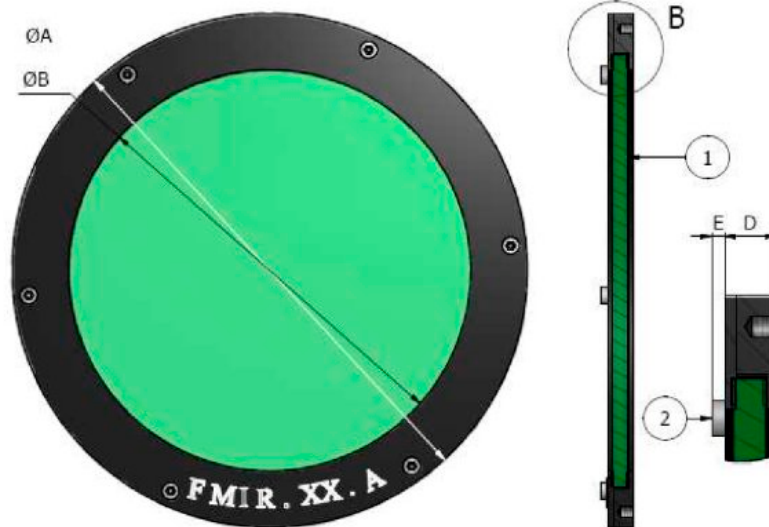

Photo FMIR.XX.I (INOX frame).

○ STANDARD DIMENSIONS :



	FMIR 30	FMIR 50	FMIR 70	FMIR 90	FMIR 110	FMIR 140	FMIR 195
Φ A	65 mm	85 mm	105 mm	125 mm	145 mm	205 mm	250 mm
Φ B	30 mm	50 mm	70 mm	90 mm	110 mm	140 mm	195 mm
D	13 mm	13 mm	13 mm	13 mm	13 mm	13 mm	13 mm
E	5 mm	5 mm	5 mm	5 mm	5 mm	5 mm	5 mm
Mark 1	Optic Φ 40/4	Optic Φ 60/4	Optic Φ 80/4	Optic Φ 100/4	Optic Φ 120/4 Φ 120/7	Optic Φ 150/6	Optic Φ 210/8
Mark 2	3 screws CHC M5x 6	3 screws CHC M5x 6	3 screws CHC M5x 6	3 screws CHC M5x 6	3 screws CHC M5x 6	6 screws CHC M5x 6	6 screws CHC M5x 6



FMIR WINDOW

○ TABLE OF MATERIALS OF OPTICAL WINDOW

Type	Material	Transmission area/ % without anti reflection treatment on 1 face	Transmission area/ % with anti reflection treatment on 1 face
0	CaF2	0,2 to 10 microns / 93%	
1	SiO2	0,2 to 1,1 microns / 93%	
2	Saphir	0,2 to 5 microns / 85 %	
3	Ge	2 to 14 microns / 45%	7 to 13 microns / 85%
4	ZnSe	0,6 to 14 microns / 70%	7 to 13 microns / 85%
5	BaF2	0,2 to 13 microns / 93%	
6	ZnS multispectral	0,4 to 14 microns / 70%	7 to 13 microns / 85%

○ ASSEMBLY

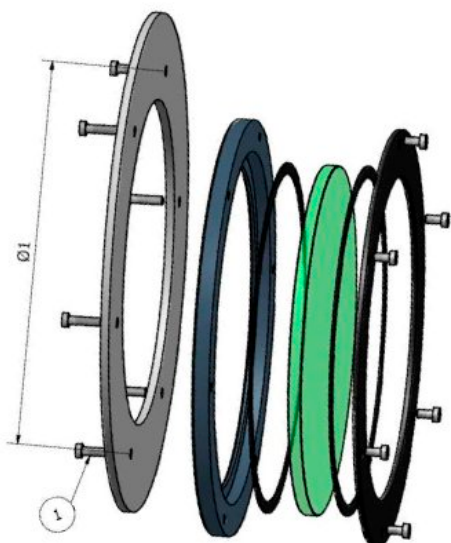

	Φ 1	Quantity Mark 1	Length of screws
FMIR 30	Φ 53	3xM5	According to thickness of the support
FMIR 50	Φ 73	3xM5	*****
FMIR 70	Φ 92	3xM5	*****
FMIR 90	Φ 112	3xM5	*****
FMIR 110	Φ 134	3xM5	*****
FMIR 140	Φ 165	6xM5	*****
FMIR 195	Φ 235	6xM5	*****

○ MONTAGE :

- Comply with the assembly plans joined in the packaging.

○ MAINTENANCE :

- In case of superficial spots, it is advisable to make a simple operation of cleaning by using some methyl alcohol and a soft cloth.