

Programmable transmitters T3110Ex, T3111Ex, T3113Ex with 4 - 20 mA outputs are designed for measurement of relative humidity and temperature in a potentially explosive environments.

Electrical devices for use in potentially explosive atmospheres are special devices that can be a source of potential danger. Such devices must be designed, installed, operated and maintained so as to not cause the explosion in potentially explosive atmosphere. The basic information about equipment intended for use in the potentially explosive atmosphere contains 2014/34/EU (ATEX) Directive.

Potentially explosive atmosphere is an area, in which could be present the mixture of air and flammable substances (gas, vapor, mist, combustible dust) in such concentration, that it may catch fire. Explosion may be initiated by a spark or hot surface.

T311xEx transmitters are intrinsically safe. It is a way of equipment protection, which is based on the limitation of energy (electrical and thermal) at a level lower than the level that could cause ignition a specific hazardous atmospheric mixture.

The principle of intrinsic safety equipment lies in limitation of the amount of electric energy supplied to electric circuits from power source and energy accumulated into parts of electric circuits. Intrinsically safe zener barriers and intrinsically safe isolation amplifiers are an elemental types of intrinsically safe interfaces designed to protect electrical circuits installed in a potentially hazardous areas.

Transmitters T311xEx in compliance with European Directive 2014/34/EU conforms to European Standards EN 60079-0:2018 and EN 60079-11:2012.

- Type Examination Certificate: **FTZÚ 13 ATEX 0189X**
- Marking: **⊕ II 3G Ex ic IIC T6 Gc**

Explanations:

- II** The product is intended to surface sites with the presence of explosive atmospheres.
- 3G** The product is intended for use in areas where an explosive mixture of gas (vapour, mist) and air is not likely to occur in normal operation and if it occurs it will exist only for a short time.
- Ex** It identifies that a protection mode against explosions has been adopted.
- ic** The protection mode by intrinsic safety according standard EN 60079-11
- IIC** The product is intended to surface sites with the presence of explosive atmosphere - subgroup of C gas
- T6** The temperature class (maximum surface temperature of the device is 85 °C at ambient temperature 60 °C)
- Gc** Equipment protection level (equipment for use in explosive atmospheres due to the presence of gas, with a level of protection "increased" that is not a source of ignition in normal operation).

The principle of connecting the T311xEx transmitters using the Zener barriers is shown in Figure. Each current loop consist of a power supply, measurement resistor, Zener barrier, transmitter and connecting wires.

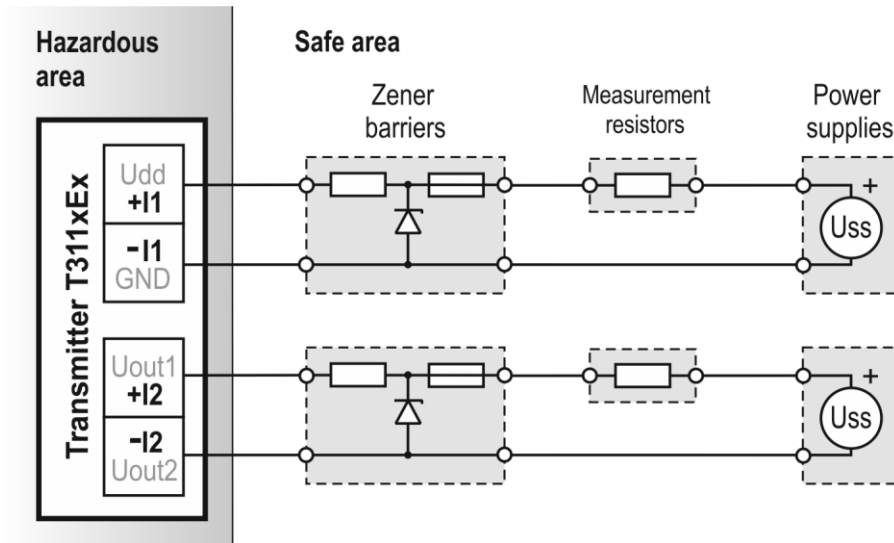

- The values of the safety parameters U_o and I_o of Zener barriers must be less than the values of intrinsically safe parameters $U_i = 30\text{ V}$ $I_i = 100\text{ mA}$ of the transmitter.
- The current loop must be designed so that the voltage at the terminals of transmitter does not fall below 9V at the maximum current $I_o = 22\text{ mA}$ (see certificate)
- The loop I1 serves also the power supply for the device and therefore must always be connected.
- Installation, commissioning and maintenance may be carried out by personnel with qualification by applicable regulations and standards.

Example of connecting a T311xEx series transmitter to two measuring equipment using a COMET Zener barrier type ZbC2 +.

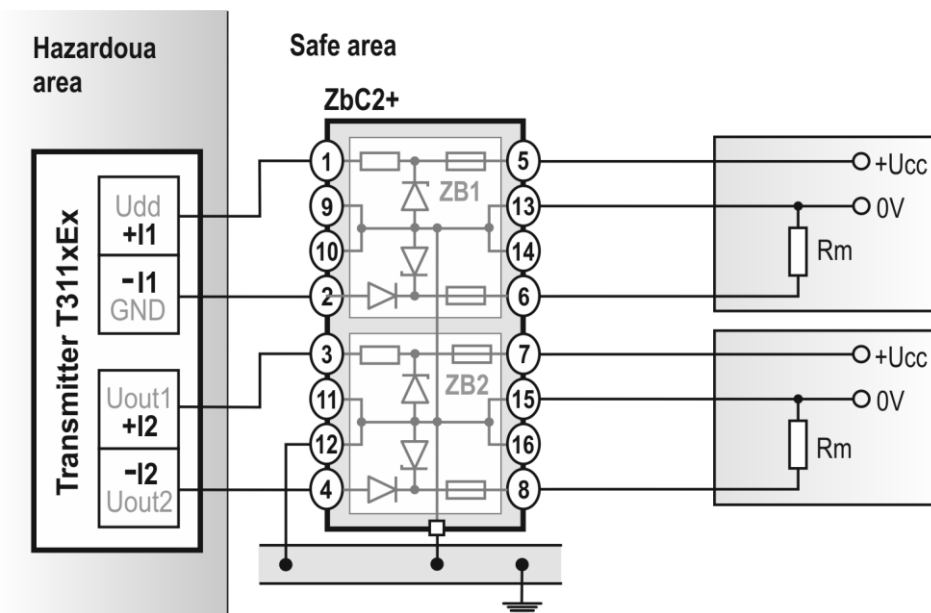

Warning: the value of the supply voltage $+U_{cc}$ must not exceed the value of the maximum allowed working voltage of the Zener barrier ($U_{wmax} = 26\text{ V}$)

Example of connecting a T311xEx series transmitter to one measuring unit using a COMET Zener barrier type ZbC2 +.

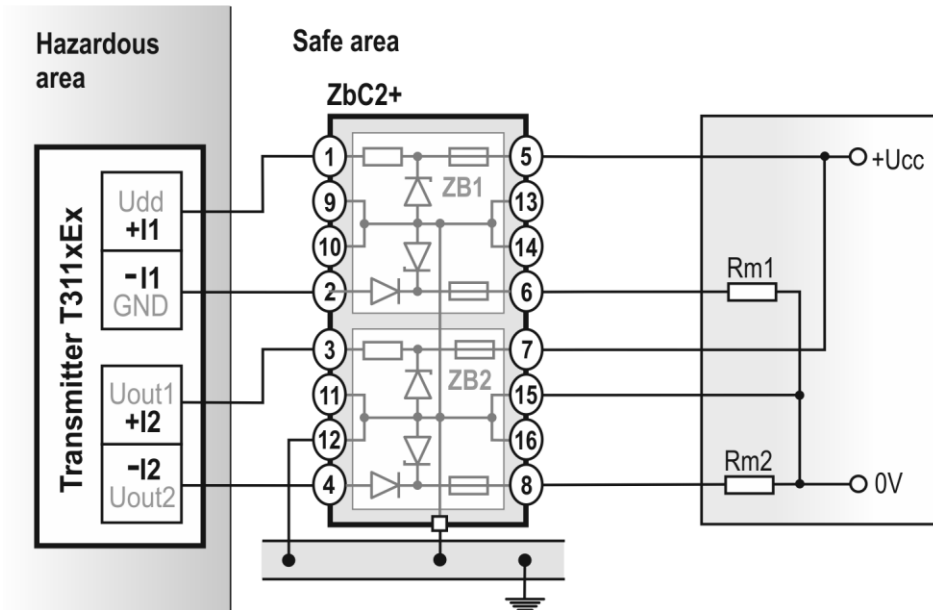

Warning: the value of the supply voltage +Ucc must not exceed the value of the maximum allowed working voltage of the Zener barrier ($U_{wmax} = 26\text{ V}$)

Example of connecting a T311xEx series transmitter to an Ethernet network using a COMET converter type P2520 and a COMET Zener barrier type ZbC2 +.

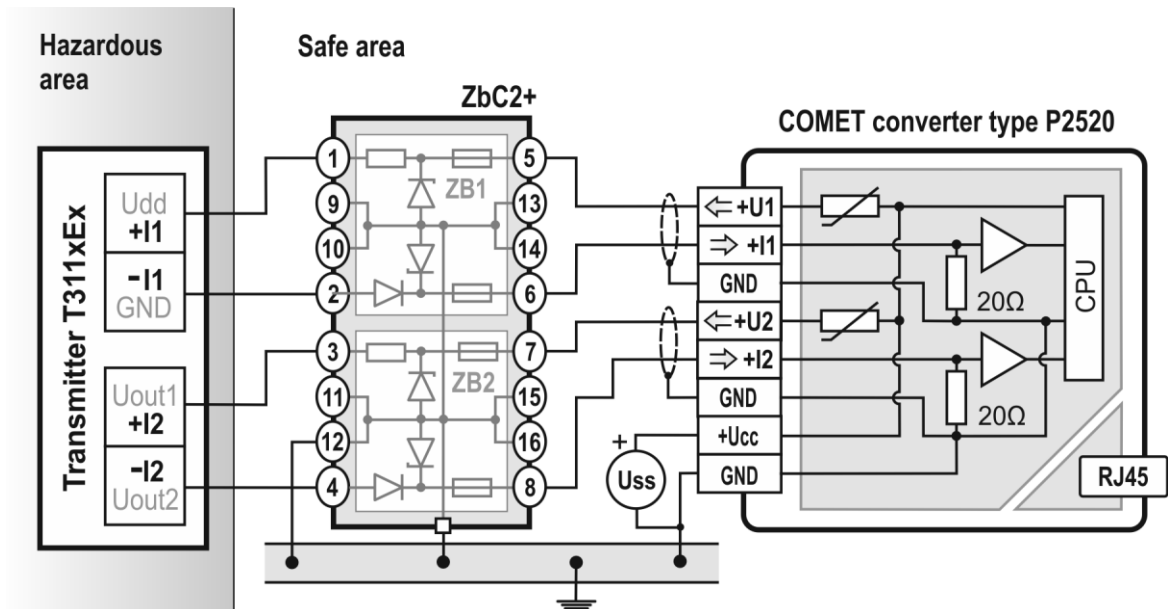

Warning: the value of the supply voltage +Uss must not exceed the value of the maximum allowed working voltage of the Zener barrier ($U_{wmax} = 26\text{ V}$). Use a stabilized 24 Vdc power supply from the recommended accessory.

Example of connection a T311xEx series transmitter to the inputs of the datalogger COMET type MS55D using the COMET Zener barrier type Zbc2 +.

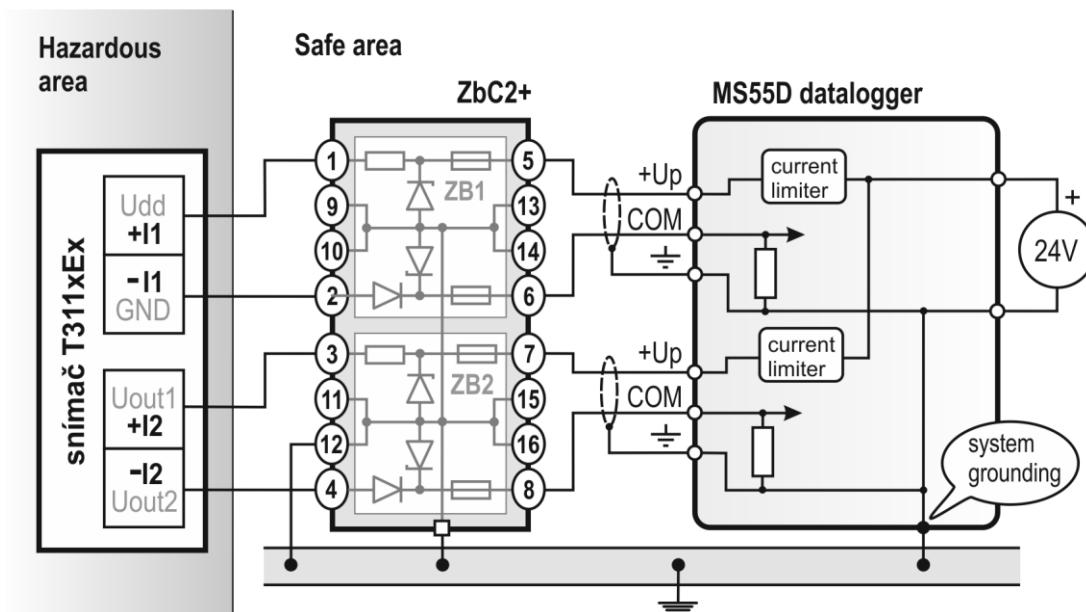

Warning: the supply voltage of the datalogger MS55D must not exceed the value of the maximum allowed working voltage of the Zener barrier ($U_{wmax} = 26$ V). Use a stabilized 24 Vdc power supply from the recommended accessory (unstabilized ac/dc adapter A1759 is not suitable for power supply).

Example of connection a T311xEx series transmitter to the inputs of the datalogger COMET type MS6 using the COMET Zener barrier type Zbc2 +.

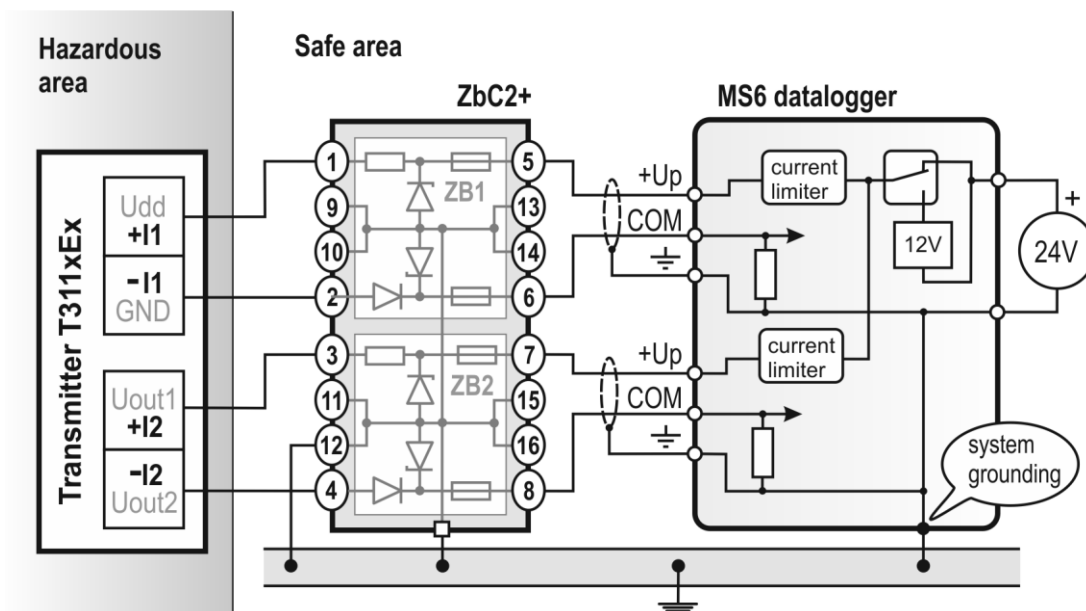

Warning: the supply voltage of the datalogger MS6 must not exceed the value of the maximum allowed working voltage of the Zener barrier ($U_{wmax} = 26$ V). Use a stabilized 24 Vdc power supply from the recommended accessory (unstabilized ac/dc adapter A1759 is not suitable for power supply).