

design features

- ✓ Heavy duty stainless steel.
- ✓ Thick polycarbonate safety shields.
- ✓ Fluted or plain tapered tubes.
- ✓ Direct reading metric and English system scales.
- ✓ Unique design facilitates ease of maintenance cleaning processes.

Heavy-duty flow meters are fully enclosed in a brushed stainless steel case. Ideal for industrial applications with flow rates of up to 116 GPM / 440 L/min and 250 SCFM / 7080 L/min. Used for flow measurements of liquids (water) and gases (air).



Meters are graduated for direct reading of water and air. Flow meters come with FNPT or flanged end fittings for easy in-line installation. Wetted parts include borosilicate glass flow tubes, FKM o-rings, and 316 Stainless steel fittings, guide rods, floats and float stops.

Flanged
M Style Meter



SPECIFICATIONS

ACCURACY	±3% of full scale.
MINIMUM FLOW RATE	Approximately 10% of maximum flow rate.
REPEATABILITY	±0.5% of full scale.
MAXIMUM PRESSURE AT 200 °F (93 °C)	200 PSIG / 13.6 bar gauge (tube size 3, 4, 5 and 6). 125 PSIG / 8.5 bar gauge (tube SIZE 8 and 9).
MAXIMUM OPERATING TEMPERATURE	200 °F (93 °C).

**MATERIALS OF CONSTRUCTION

FLOW TUBES	Heavy walled borosilicate glass.
FITTINGS IN CONTACT WITH FLUIDS	316 Stainless Steel.
FRONT SHIELD	Thick clear polycarbonate and white acrylics.
O-RINGS	FKM.
OPTIONAL	PTFE/ FFKM, EPR.
CONNECTIONS	IN LINE: 1/2", 1-1/2", 2", NPT. 150 ANSI FLANGED: 3/4", 1-1/2", 2-1/2".

***The selection of materials of construction, is the responsibility of the customer. The company accepts no liability.*

M

ORDERING INFORMATION STAINLESS INDUSTRIAL FLOW METERS

Configure and Order Online: [Model M Industrial Flow Meters](#)

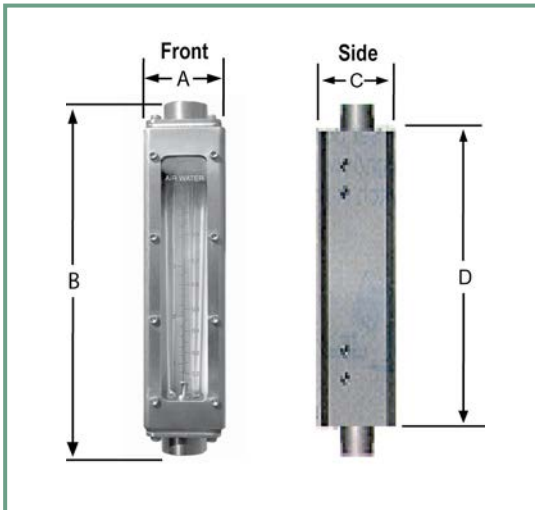

DIMENSIONS FOR IN-LINE M STYLE METERS

NPT (F)	A	B	C	D
1/2"	2	9.54	2.25	8.04
1"	3.5	13.69	3.75	10.50
2"	5	15.59	5.25	11.55

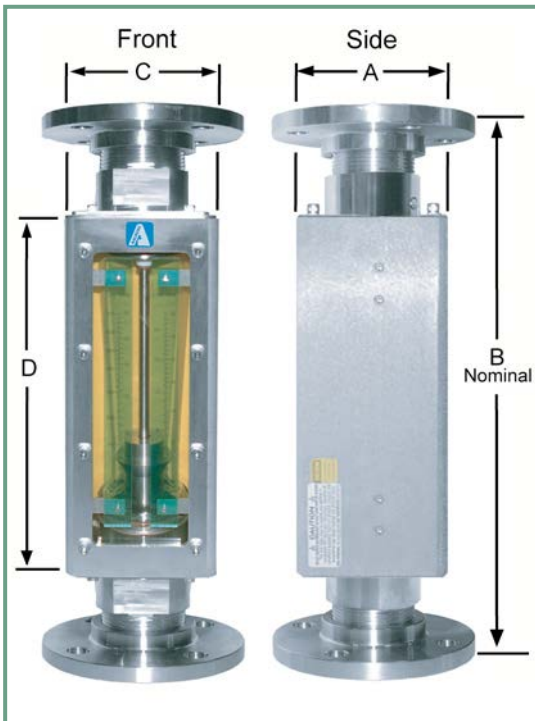

DIMENSIONS FOR FLANGED M STYLE METERS

Flange Size	A	B (Nominal)	C	D
3/4"	2	9.58	2.25	8.04
1 1/2"	3.5	14.15	3.75	10.50
2 1/2"	5	17.98	5.25	11.55

IN LINE M STYLE METERS

CATALOG NUMBER	MAX FLOW RATE				PRESSURE DROP (OF H ₂ O)	TUBE SIZE	NPT CONNECTION
	WATER [GPM]	AIR [SCFM]	WATER [L/min]	AIR [L/min]			
MS-VJ-M01-02-ST	0.25	1.2	.95	35	3	3	1/2"
MS-VJ-M02-02-ST	0.36	1.9	1.3	54	3	3	
MS-VJ-M03-02-ST	0.76	3.3	3.0	90	7	3	
MS-VJ-M04-02-ST	1.0	4.2	3.8	120	8	4	
MS-VJ-M05-02-ST	1.5	6.5	5.6	180	11	4	
MS-VJ-M06-02-ST	2.2	8.5	8.2	250	14	4	
MS-VK-M07-02-ST	3.8	16	14	480	14	5	1"
MS-VK-M08-02-ST	5.0	22	18	650	20	5	
MS-VK-M09-02-ST	6.0	25	22	725	7	6	
MS-VK-M10-02-ST	7.4	34	27.5	950	8	6	
MS-VK-M11-02-ST	9.6	40	36	1200	14	6	
MS-VK-M12-02-ST	11	47.5	42	1400	18	6	
MS-VK-M13-02-ST	15	62.5	57.5	1800	34	6	2"
MS-VK-M14-02-ST	20	90	80	2600	55	6	
MS-VL-M15-02-ST	22	90	85	2550	23	8	1"
MS-VK-M16-02-ST	25	-	95	-	99	6	
MS-VQ-M17-02-ST	41	170	155	4600	7	9	2"
MS-VL-M18-02-ST	44	180	165	5000	42	8	
MS-VQ-M19-02-ST	60	250	230	7000	23	9	
MS-VL-M20-02-ST	62	250	230	7000	70	8	
MS-VQ-M21-02-ST	86	-	320	-	35	9	
MS-VQ-M22-02-ST	116	-	440	-	56	9	

FLANGED M STYLE METERS

CATALOG NUMBER	MAX FLOW RATE				PRESSURE DROP (OF H ₂ O)	TUBE SIZE	FLANGE CONNECTION
	WATER [GPM]	AIR [SCFM]	WATER [L/min]	AIR [L/min]			
MS-VR-M01-02-ST	0.25	1.2	.95	35	3	3	3/4"
MS-VR-M02-02-ST	0.36	1.9	1.3	54	3	3	
MS-VR-M03-02-ST	0.76	3.3	3.0	90	7	3	
MS-VR-M04-02-ST	1.0	4.2	3.8	120	8	4	
MS-VR-M05-02-ST	1.5	6.5	5.6	180	11	4	
MS-VR-M06-02-ST	2.2	8.5	8.2	250	14	4	
MS-VS-M07-02-ST	3.8	16	14	480	14	5	1 1/2"
MS-VS-M08-02-ST	5.0	22	18	650	20	5	
MS-VS-M09-02-ST	6.0	25	22	725	7	6	
MS-VS-M10-02-ST	7.4	34	27.5	950	8	6	
MS-VS-M11-02-ST	9.6	40	36	1200	14	6	
MS-VS-M12-02-ST	11	47.5	42	1400	18	6	
MS-VS-M13-02-ST	15	62.5	57.5	1800	34	6	2 1/2"
MS-VS-M14-02-ST	20	90	80	2600	55	6	
MS-VT-M15-02-ST	22	90	85	2550	23	8	1 1/2"
MS-VS-M16-02-ST	25	-	95	-	99	6	
MS-VU-M17-02-ST	41	170	155	4600	7	9	2 1/2"
MS-VT-M18-02-ST	44	180	165	5000	42	8	
MS-VU-M19-02-ST	60	250	230	7000	23	9	
MS-VT-M20-02-ST	62	250	230	7000	70	8	
MS-VU-M21-02-ST	86	-	320	-	35	9	
MS-VU-M22-02-ST	116	-	440	-	56	9	

NOTE: Aalborg® reserves the right to change designs and dimensions at its sole discretion at any time without notice. For certified dimensions please contact Aalborg®.
47 WWW.AALBORG.COM ● E-MAIL ✉ INFO@AALBORG.COM ● PHONE ☎ **845.770.3000** ● TOLL FREE IN U.S.A. AND CANADA **1.800.866.3837** ● ORANGEBURG N.Y. U.S.A.