

User Guide

Vaisala Indigo-compatible
dew point and temperature probes

DMP Series

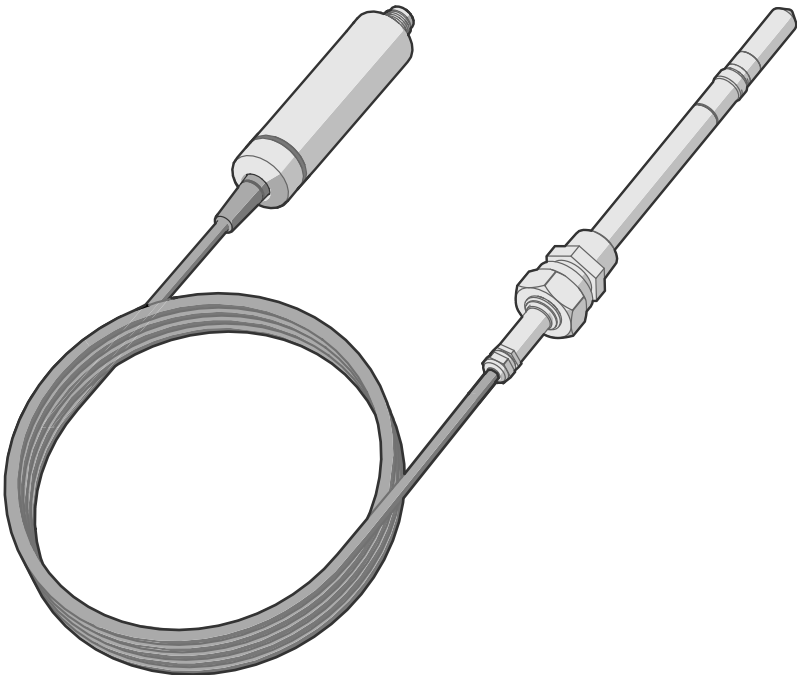

VAISALA

PUBLISHED BY

Vaisala Oyj
Vanha Nurmijärventie 21, FI-01670 Vantaa, Finland
P.O. Box 26, FI-00421 Helsinki, Finland
+358 9 8949 1
www.vaisala.com
docs.vaisala.com

© Vaisala 2023

No part of this document may be reproduced, published or publicly displayed in any form or by any means, electronic or mechanical (including photocopying), nor may its contents be modified, translated, adapted, sold or disclosed to a third party without prior written permission of the copyright holder. Translated documents and translated portions of multilingual documents are based on the original English versions. In ambiguous cases, the English versions are applicable, not the translations.

The contents of this document are subject to change without prior notice.

Local rules and regulations may vary and they shall take precedence over the information contained in this document. Vaisala makes no representations on this document's compliance with the local

rules and regulations applicable at any given time, and hereby disclaims any and all responsibilities related thereto.

This document does not create any legally binding obligations for Vaisala towards customers or end users. All legally binding obligations and agreements are included exclusively in the applicable supply contract or the General Conditions of Sale and General Conditions of Service of Vaisala.

This product contains software developed by Vaisala or third parties. Use of the software is governed by license terms and conditions included in the applicable supply contract or, in the absence of separate license terms and conditions, by the General License Conditions of Vaisala Group.

Table of contents

1.	About this document	9
1.1	Version information.....	9
1.2	Related manuals.....	10
1.3	Documentation conventions.....	11
1.4	Trademarks.....	12
2.	Product overview	13
2.1	Probe structure.....	13
2.2	Basic features and options.....	13
2.3	Output parameters.....	14
2.4	Additional features with Indigo transmitters.....	15
2.5	Safety.....	15
2.6	ESD protection.....	16
2.7	Regulatory statements.....	16
2.7.1	FCC Part 15 compliance statement.....	16
2.7.2	Canada ICES-3 / NMB-3 compliance statement.....	17
3.	Functional description	18
3.1	DRYCAP® technology.....	18
3.1.1	DRYCAP® sensor models in DMP Series probes.....	18
3.2	Autocalibration.....	18
3.3	Sensor purge.....	19
3.4	Condensation prevention functions.....	19
3.5	Environmental compensation.....	20
3.6	Filtering factor.....	21
4.	Installation	22
4.1	DMP5 probe.....	23
4.1.1	Installing with Mounting Flange 210696.....	24
4.2	DMP6 probe.....	25
4.2.1	Installing probe head with Cooling Set DMP246CS.....	27
4.2.2	Cooling Set installation example.....	29
4.3	DMP7 probe.....	30
4.3.1	Pressure-tight Swagelok installation kit.....	30
4.4	DMP8 probe.....	32
4.4.1	Tightening the clasp nut.....	34
4.4.2	DMT242SC sampling cell.....	34
4.4.3	DMT242SC2 sampling cell with Swagelok connectors.....	35
4.5	Wiring.....	36
4.6	Configuring environmental compensations.....	37
5.	Configuration with Insight software	38
5.1	Vaisala Insight software.....	38
5.2	Connecting to Insight software.....	38
5.3	Configuration options.....	39
5.4	Diagnostics in Insight.....	40

- 6. Using probe with Indigo transmitters..... 42**
 - 6.1 Connecting probe to Indigo200 series transmitters..... 42
 - 6.2 Connecting probe to Indigo300 transmitter..... 43
 - 6.3 Connecting probes to Indigo500 series transmitters..... 44

- 7. Using probe with Indigo80 handheld indicator..... 46**
 - 7.1 Indigo80 handheld indicator..... 46
 - 7.1.1 Probe compatibility..... 47
 - 7.1.2 Indigo80 keypad..... 47
 - 7.1.3 Indigo80 main menu..... 47
 - 7.2 Connecting probes to Indigo80..... 48
 - 7.3 Configuring probe features with Indigo80 handheld indicator..... 49
 - 7.3.1 Example of configuring filtering factor with Indigo80 handheld indicator..... 50
 - 7.4 Configuring environment settings with Indigo80 handheld indicator.... 51

- 8. Maintenance..... 53**
 - 8.1 Cleaning the probe..... 53
 - 8.2 Changing the probe filter..... 53
 - 8.3 Calibration and adjustment..... 54

- 9. Troubleshooting..... 55**
 - 9.1 Problem situations..... 55
 - 9.2 Error messages..... 55
 - 9.3 Restoring factory default settings with Insight software..... 57
 - 9.4 Restoring factory default settings with Indigo80 handheld indicator... 58

- 10. Technical data..... 59**
 - 10.1 DMP5 specifications..... 59
 - 10.2 DMP6 specifications..... 61
 - 10.3 DMP7 specifications..... 66
 - 10.4 DMP8 specifications..... 68
 - 10.5 Accessories and spare parts..... 71

- Appendix A: Modbus reference..... 75**
 - A.1 Default communication settings..... 75
 - A.2 Function codes..... 75
 - A.3 Data encoding..... 75
 - A.3.1 32-bit floating point or 32-bit integer format..... 76
 - A.3.2 16-bit integer format..... 76
 - A.4 Modbus registers..... 77
 - A.4.1 Measurement data registers..... 77
 - A.4.2 Diagnostic data registers..... 79
 - A.4.3 Configuration registers..... 79
 - A.4.4 Status registers..... 81
 - A.4.5 Test value registers..... 83
 - A.5 Device identification objects..... 83
 - A.6 Exception responses..... 84

A.7	Modbus communication examples.....	85
	Maintenance and calibration services.....	89
	Warranty.....	89
	Technical support.....	89
	Recycling.....	89

List of figures

Figure 1	Probe parts.....	13
Figure 2	Example installation.....	22
Figure 3	DMP5 dimensions.....	23
Figure 4	DMP6 probe dimensions.....	25
Figure 5	Cooling Set DMP246CS dimensions.....	25
Figure 6	Operating range of DMP6 probe head.....	26
Figure 7	DMP246CS Cooling Set mounting flange.....	27
Figure 8	DMP246CS Cooling Set without mounting flange.....	28
Figure 9	Example installation with Cooling Set DMP246CS.....	29
Figure 10	DMP7 dimensions.....	30
Figure 11	DMP7 installation to pipeline using a Swagelok installation kit.....	31
Figure 12	DMP8 dimensions.....	32
Figure 13	DMP8 probe head.....	33
Figure 14	Sealing of fitting body into process.....	33
Figure 15	Sampling cells DMT242SC2 (left) and DMT242SC (right).....	35
Figure 16	M12 5-pin A-coded male connector pinout.....	36
Figure 17	RS-485 wiring.....	36
Figure 18	Connecting probe to Insight using Indigo USB adapter.....	39
Figure 19	DMP5 in Insight software.....	40
Figure 20	DMP5 diagnostics in Insight (advanced mode).....	41
Figure 21	Connecting probe to Indigo200 series transmitter.....	43
Figure 22	Connecting probe to Indigo300 transmitter.....	44
Figure 23	Connecting probes to Indigo500 transmitter.....	45
Figure 24	Indigo80 handheld indicator.....	46
Figure 25	Indigo80 keypad.....	47
Figure 26	Indigo80 main menu.....	47
Figure 27	Connecting probes to Indigo80.....	48
Figure 28	DMP5 dew point accuracy vs. measurement conditions.....	60
Figure 29	DMP5 dimensions.....	61
Figure 30	Operating range of DMP6 probe head.....	63
Figure 31	DMP6 dimensions with Cooling Set DMP246CS.....	64
Figure 32	DMP6 probe dimensions.....	65
Figure 33	Cooling Set DMP246CS dimensions.....	65
Figure 34	DMP7 dew point accuracy vs. measurement conditions.....	67
Figure 35	DMP7 dimensions.....	68
Figure 36	DMP8 dew point accuracy vs. measurement conditions.....	69
Figure 37	DMP8 dimensions.....	71

List of tables

Table 1	Document versions (English).....	9
Table 2	Related manuals.....	11
Table 3	Availability of output parameters.....	14
Table 4	DRYCAP® sensor models in DMP Series probes.....	18
Table 5	Troubleshooting table.....	55
Table 6	DMP5 measurement performance.....	59
Table 7	DMP5 operating environment.....	60
Table 8	DMP5 inputs and outputs.....	60
Table 9	DMP5 mechanical specifications.....	61
Table 10	DMP6 measurement performance.....	61
Table 11	DMP6 operating environment.....	62
Table 12	DMP6 inputs and outputs.....	63
Table 13	DMP6 mechanical specifications.....	63
Table 14	DMP7 measurement performance.....	66
Table 15	DMP7 operating environment.....	67
Table 16	DMP7 inputs and outputs.....	67
Table 17	DMP7 mechanical specifications.....	68
Table 18	DMP8 measurement performance.....	68
Table 19	DMP8 operating environment.....	70
Table 20	DMP8 inputs and outputs.....	70
Table 21	DMP8 mechanical specifications.....	70
Table 22	Connection cables.....	71
Table 23	DMP5 accessories.....	72
Table 24	DMP5 spare parts.....	72
Table 25	DMP6 accessories.....	72
Table 26	DMP6 spare parts.....	72
Table 27	DMP7 accessories.....	73
Table 28	DMP7 spare parts.....	73
Table 29	DMP8 accessories.....	73
Table 30	DMP8 spare parts.....	73
Table 31	Default Modbus serial communication settings.....	75
Table 32	Modbus function codes.....	75
Table 33	Interpretation of 16-bit signed integer values.....	76
Table 34	Floating point measurement data registers (read-only).....	77
Table 35	Integer measurement data registers (read-only).....	78
Table 36	Floating point diagnostic data registers (read-only).....	79
Table 37	Integer diagnostic data registers (read-only).....	79
Table 38	Modbus configuration data registers (writable).....	79
Table 39	Modbus status data registers (read-only).....	81
Table 40	Error codes in register 0203 _{hex}	82
Table 41	Modbus test registers (read-only).....	83
Table 42	Device identification objects.....	83
Table 43	Modbus exception responses.....	84

1. About this document

1.1 Version information

This document provides instructions for installing, using, and maintaining Vaisala DRYCAP® Dew Point and Temperature Probes DMP5, DMP6, DMP7, and DMP8.

Table 1 Document versions (English)

Document code	Date	Description
M212357EN-D	June 2023	<p>Applicable from software version 1.2.8 onward.</p> <p>Added sensor saturation ration (SSR) and sensor temperature (T_s) parameters to Output parameters (page 14).</p> <p>Updated information on external temperature sources in Environmental compensation (page 20).</p> <p>Updated sections DMP6 probe (page 25) and DMP6 specifications (page 61) with a caution about high air flows.</p> <p>Added information on the Indigo300 transmitter and updated information on other Indigo transmitters in:</p> <ul style="list-style-type: none"> • Additional features with Indigo transmitters (page 15) • Using probe with Indigo transmitters (page 42) <p>Updated information on connection cables in Accessories and spare parts (page 71). Updated accessories and spare parts information for DMP6, DMP7 and DMP8.</p>

Document code	Date	Description
M212357EN-C	March 2023	<p>Added information on the Indigo80 handheld indicator, condensation prevention (sensor warming), environmental compensation and filtering factor.</p> <p>Added sections:</p> <ul style="list-style-type: none"> • Condensation prevention functions (page 19) • Environmental compensation (page 20) • Filtering factor (page 21) • Configuring environmental compensations (page 37) • Using probe with Indigo80 handheld indicator • Restoring factory default settings with Indigo80 handheld indicator (page 58) <p>Updated sections:</p> <ul style="list-style-type: none"> • Product overview (page 13) • Calibration and adjustment (page 54) • Accessories and spare parts (page 71) • Configuration registers (page 79) <p>Updated information on the ball valve in section DMP8 probe (page 32). Removed section <i>Attaching ball valve kit to process</i>.</p> <p><i>Indigo200 series transmitters</i> revised to describe the current Indigo200 transmitters compatible with the Insight PC software.</p> <p>Removed sections <i>Sensor warming</i> and <i>Extra heat</i>.</p>
M212357EN-B	June 2022	<p>Updated sections:</p> <ul style="list-style-type: none"> • DRYCAP® sensor models in DMP Series probes (page 18) • Sensor purge (page 19) • DMP6 probe (page 25) • DMP7 probe (page 30) • Vaisala Insight software (page 38) • Error messages (page 55) • <i>Mechanical specifications</i> tables and dimension drawings in chapter <i>Technical data</i>

1.2 Related manuals



For the latest versions of these documents, see docs.vaisala.com.

Table 2 Related manuals

Document code	Name
M212356EN	Vaisala DMP Series Quick Guide
M212842EN	Vaisala Indigo201 Analog Output Transmitter User Guide
M212843EN	Vaisala Indigo202 Digital Transmitter User Guide
M212287EN	Vaisala Indigo500 Series Transmitters User Guide
M212722EN	Vaisala Indigo80 Handheld Indicator User Guide

1.3 Documentation conventions



WARNING! Warning alerts you to a serious hazard. If you do not read and follow instructions carefully at this point, there is a risk of injury or even death.



CAUTION! Caution warns you of a potential hazard. If you do not read and follow instructions carefully at this point, the product could be damaged or important data could be lost.



Note highlights important information on using the product.



Tip gives information for using the product more efficiently.



Lists tools needed to perform the task.



Indicates that you need to take some notes during the task.

1.4 Trademarks

Vaisala® and DRYCAP® are registered trademarks of Vaisala Oyj.

All other product or company names that may be mentioned in this publication are trade names, trademarks, or registered trademarks of their respective owners.

2. Product overview

DMP series probes are dew point and temperature measurement probes with a digital output (Modbus® protocol). The probes are designed for demanding dew point measurement applications. The probes have a two-part structure, with measurement electronics contained in the probe body and sensor(s) in the probe head. The probe body and the probe head are connected by a fixed cable. Length options for this connecting cable depend on the probe model.

The probes are compatible with Vaisala Indigo transmitters and Vaisala Indigo80 Handheld Indicator. They can also be connected to Vaisala Insight PC software for configuration, calibration, diagnostics, and temporary online monitoring.

2.1 Probe structure

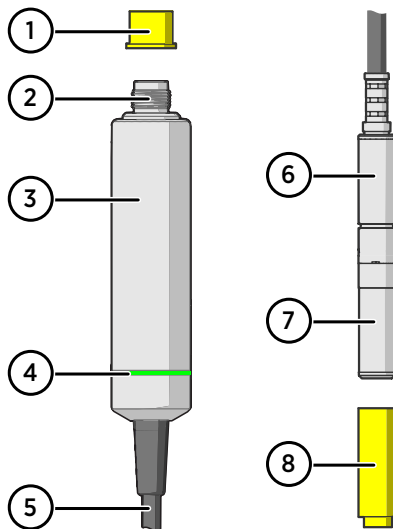

Figure 1 Probe parts

- | | |
|---|---|
| 1 | Protection cap (remove before use) |
| 2 | 5-pin M12 connector |
| 3 | Probe body with type label |
| 4 | Status indicator LED: |
| | Green Power on and probe online, flashes when communicating |
| | Red Error |
| | Off Power off, or indicator disabled |
| 5 | Fixed probe cable, variable length (do not cut). |
| 6 | Probe head (DMP7 model shown) |
| 7 | Location of sensors on the probe head. DMP series probes have a removable filter over the sensors that can be replaced if it gets dirty or damaged. |
| 8 | Protection cap (remove before use) |

2.2 Basic features and options

- Comprehensive list of output parameters
- Sensor purge provides superior chemical resistance
- Condensation prevention feature minimizes condensation on probe
- Traceable calibration certificate
- Standalone Modbus® RTU over RS-485
- Compatible with Indigo transmitters and Indigo80 handheld indicator

- Can be connected to Vaisala Insight PC software for configuration, calibration, diagnostics, and temporary online monitoring

2.3 Output parameters



Values of all available output parameters are locked (showing the latest valid value) when sensor purge, autocalibration, or condensation prevention functions are active.

- Output parameter is available on this model.
- ◐ Output parameter is unavailable during sensor warming unless temperature is written to register 0334_{hex} from an external source
- Output parameter is not available on this model.

Table 3 Availability of output parameters

Output parameter	Output unit	DMP5	DMP6	DMP7	DMP8
Relative humidity	%RH	◐	–	◐	◐
Temperature	°C	◐	–	◐	◐
Dew point temperature	°C	●	●	●	●
Dew/frost point temperature	°C	●	●	●	●
Dew/frost point temperature at 1 atm	°C	●	●	●	●
Dew point temperature at 1 atm	°C	●	●	●	●
Absolute humidity	g/m ³	◐	–	◐	◐
Mixing ratio	g/kg	●	●	●	●
Water concentration	ppm _v	●	●	●	●
Water vapor pressure	hPa	●	●	●	●
Water vapor saturation pressure	hPa	◐	–	◐	◐
Enthalpy	kJ/kg	◐	–	◐	◐
Dew point temperature difference	°C	◐	–	◐	◐
Absolute humidity at NTP	g/m ³	◐	–	◐	◐
Water mass fraction	ppm _w	●	●	●	●
Diagnostic parameters ¹⁾					
Sensor saturation ratio (SSR)	%	–	●	–	–

Output parameter	Output unit	DMP5	DMP6	DMP7	DMP8
Sensor temperature (T _s)	°C	–	●	–	–

- 1) *Selectable as output parameters using the Indigo80 handheld indicator and the Modbus protocol.*

2.4 Additional features with Indigo transmitters

Connecting the probe to an Indigo transmitter provides a wide range of additional options for outputs, measurement viewing, status monitoring, and configuration interface access.

Examples of additional features available with Indigo520 transmitters:

- Touchscreen display for real-time data viewing and configuration
- Support for 2 probes simultaneously
- 4 configurable analog outputs
- 2 configurable relays
- 2-wire current loop analog input
- Barometer module for barometric pressure measurement (optional module)
- Ethernet connection with web interface for remote access
- Modbus TCP/IP protocol
- Service port for connecting to Indigo80 handheld indicator

Examples of additional features available with Indigo300 transmitters:

- Numerical and graphical display for real-time data viewing
- 3 pre-configurable analog outputs
- Service port on the front for connecting to Vaisala Insight PC software or Indigo80 handheld indicator for easy configuration access

Examples of additional features available with Indigo200 series transmitters:

- 3.5" TFT LCD color display or non-display model with LED indicator
- Digital output or 3 analog outputs (depending on the transmitter model)
- 2 configurable relays
- USB-C connection to Vaisala Insight PC software for easy configuration access



Available features vary depending on the Indigo transmitter model. For more information on Indigo transmitters, see www.vaisala.com/indigo.

2.5 Safety



WARNING! When returning a product for calibration or repair, make sure it has not been exposed to dangerous contamination, and is safe to handle without special precautions.



CAUTION! Do not attempt to open the probe body. There are no user serviceable parts inside the probe body.



CAUTION! Do not touch the probe head with your bare hands. Touching will deposit impurities on the probe head.

2.6 ESD protection

Electrostatic discharge (ESD) can cause immediate or latent damage to electronic circuits. Vaisala products are adequately protected against ESD for their intended use. However, it is possible to damage the product by delivering an electrostatic discharge when touching, removing or inserting any objects inside the equipment housing.

Avoid touching component contacts or connectors when working with the device.

2.7 Regulatory statements

2.7.1 FCC Part 15 compliance statement

This equipment has been tested and found to comply with the limits for a Class B digital device, pursuant to Part 15 of the FCC rules. These limits are designed to provide reasonable protection against harmful interference in a residential installation. This equipment generates, uses and can radiate radio frequency energy and, if not installed and used in accordance with the instructions, may cause harmful interference to radio communications. However, there is no guarantee that the interference will not occur in a particular installation. If this equipment does cause harmful interference to radio or television reception, which can be determined by turning the equipment off and on, the user is encouraged to try to correct the interference by one or more of the following measures:

- Reorient or relocate the receiving antenna.
- Increase the separation between the equipment and receiver.
- Connect the equipment into an outlet on a circuit different from that to which the receiver is connected.
- Consult the dealer or an experienced radio/TV technician for help.



CAUTION! Changes or modifications to this equipment not expressly approved by the party responsible for compliance could void the user's authority to operate the equipment.



This device complies with part 15 of the FCC Rules. Operation is subject to the following two conditions: (1) This device may not cause harmful interference, and (2) this device must accept any interference received, including interference that may cause undesired operation.

2.7.2 Canada ICES-3 / NMB-3 compliance statement

This Class B digital apparatus complies with Canadian ICES-003.

Cet appareil numérique de la classe B est conforme à la norme NMB-003 du Canada.

3. Functional description

3.1 DRYCAP® technology

Vaisala DRYCAP® dew point measurement technology ensures accurate measurement with excellent long term stability. Its unrivalled performance is based on two innovations: the proven capacitive thin-film polymer sensor and the self-diagnostic functions that the software performs automatically as needed.

The sensor's thin-film polymer absorbs or releases water vapor as the surrounding humidity increases or decreases. The dielectric properties of the polymer change as the humidity around the sensor changes, as does the capacitance of the sensor. Capacitance is converted into a humidity reading. The capacitive polymer sensor is bonded together with a temperature sensor, and dew point is calculated from the humidity and temperature readings.

The automatic sensor functions are called autocalibration, sensor purge, and sensor warming. They are a key element in achieving the stability, rapid response time, and condensation resistance of the DRYCAP® sensors.

3.1.1 DRYCAP® sensor models in DMP Series probes

Table 4 DRYCAP® sensor models in DMP Series probes

Probe model	Sensor variant	Suitable applications
DMP5	DRYCAP® 180S	Humid applications such ovens and refrigeration dryers
DMP6		
DMP7	DRYCAP® 180M	Standard dry gas and desiccant dryer applications
DMP8		

3.2 Autocalibration

Autocalibration of the DRYCAP sensor optimizes measurement stability in dry environments. During autocalibration the sensor is warmed for a short period (< 1 min) and the sensor capacitance values are evaluated at the elevated temperature. The possible dry end drift is then corrected to correspond to the calibrated values. During autocalibration the values of all available output parameters are locked (showing the latest valid value).

DMP series probes perform autocalibration at 1-hour intervals, and whenever sensor purge is performed. When measuring very dry conditions, the probe performs autocalibration at shorter intervals. A significant change in dew point or temperature may also trigger autocalibration.

Autocalibration is carried out only if several criteria for the measurement environment are fulfilled. This ensures the reliability of the adjustments, and maintains the excellent long term stability that the patented technology offers. These criteria include, for example, a stable enough moisture level in the measured atmosphere. If the conditions are not fulfilled, the autocalibration function is postponed until satisfactory conditions are reached.

Sometimes autocalibration fails to complete successfully due to changes in measurement conditions. This is normal, and is not a problem as autocalibration will be reattempted automatically. However, autocalibration should eventually succeed to maintain the accuracy of the probe.

3.3 Sensor purge

Sensor purge is an automatic procedure that minimizes the drift at the wet end readings of the dew point measurement. The sensor is heated to a high temperature which evaporates all excess molecules out of the sensor polymer. This, together with autocalibration, results in a very small drift of the sensor due to the very linear behavior of the polymer technology.

By default, DMP probes perform sensor purge when they are powered on (known as **startup purge**), and at one day intervals (known as **interval purge**). If necessary, the purge settings can be configured with the Insight software, the Indigo80 handheld indicator, or using the Modbus protocol. However, Vaisala recommends leaving the sensor purge settings at their default values.

As with autocalibration, during sensor purge the values of the measurement parameters are frozen at their last measured values prior to the procedure.

3.4 Condensation prevention functions

The sensor warming feature of the condensation prevention function is intended for improving the condensation tolerance of the probe. It warms the humidity sensor when necessary to keep the sensor's temperature above the dew point of the measurement environment. When sensor warming is activated, all temperature-dependent output parameters become unavailable, unless the temperature compensation setting is set to read the temperature from an external source. The output parameters become available again 4 minutes after the warming is stopped.

The humidity limit where sensor warming activates is:

- 80 %RH for DMP probes with S sensors
- 70 %RH for DMP probes with M sensors

In addition, the DRYCAP® sensor is kept continuously warmed in freezing conditions to ensure fast response time. Therefore, the temperature and dependent parameters are continuously unavailable if process temperature is below 0 °C / 32 °F.

3.5 Environmental compensation

Environmental compensations improve the measurement accuracy of the probe. You can configure the settings with the Insight software or the Indigo80 handheld indicator, or using the Modbus protocol.

Pressure compensation

The pressure of the measured environment affects the accuracy of humidity calculations, especially calculations that are dependent on pressure (for example, mixing ratio). To achieve accurate output of all humidity parameters, you are recommended to update the value of the pressure compensation setpoint to match the environmental pressure when installing the probe.

For example, when you install the probe in a process with a pressure differing from normal atmospheric pressure, update the correct pressure into the pressure compensation setpoint parameter or register of the probe using the Insight software or the Indigo80 handheld indicator.

The current value is stored in non-volatile memory when the device is turned off, and restored at power-up.

Using the Modbus protocol, it is also possible to set the value to be read constantly from an external source, such as a pressure indicator.

Temperature compensation

You need to set an external source for the temperature compensation setpoint if the sensor warming feature of the condensation prevention function prevents the probe's own temperature measurement, and the output parameters that require temperature information to be known are required.

When warming is active, values of output parameters that depend on temperature measurement (for example, relative humidity) are unavailable, unless temperature information is read from an external source. Output parameters that can be measured or calculated without this external temperature information, such as dew point temperature, are available even without the temperature input.

The external temperature source can be another probe (for example, TMP1) that is connected to the same Indigo80 handheld indicator as your probe. It is also possible to use your own host system for updating the temperature value to your probe through the Modbus interface.

To get the most accurate measurement values, the external source needs to be able to provide the temperature compensation setpoint value constantly in real time, and the value needs to correspond to the temperature of the probe's measurement environment as accurately as possible. A suitable measurement point is as close to the probe as possible, but yet far enough so that ongoing condensation prevention warming of the probe does not have an effect on the measured value.

At device reset, the value is cleared.

More information

- [Configuring environment settings with Indigo80 handheld indicator \(page 51\)](#)

3.6 Filtering factor

The filtering factor determines how quickly the results of measurement cycles are reflected in values of output parameters. You can use the filtering factor to slow down the response time of the measurement, filtering out rapid changes and measurement noise.

- Maximum value (1) = No filtering, fastest measurement. Output shows 100% of the most recent measured value.
- Less than maximum value = Filtering is applied and measurement response time is reduced. For example, defining a value that is 90% of the maximum value means that the filtered output reading = 90% of the most recent measured value + 10% of the previous reading.

Filtering factor settings can be configured with the Insight software, the Indigo80 handheld indicator, or using the Modbus protocol.

More information

- [Example of configuring filtering factor with Indigo80 handheld indicator \(page 50\)](#)

4. Installation

When you choose the installation location for the probe, consider the following:

- Verify the operating environment specification of the probe model. The probe head typically has a much wider operating temperature range than the probe body.
- If the temperature of the measured environment differs greatly from ambient temperature, the entire probe head and preferably plenty of cable must be inside the measured environment. This prevents measurement inaccuracy caused by heat conduction along the cable.
- Probe mounting options are model-specific.

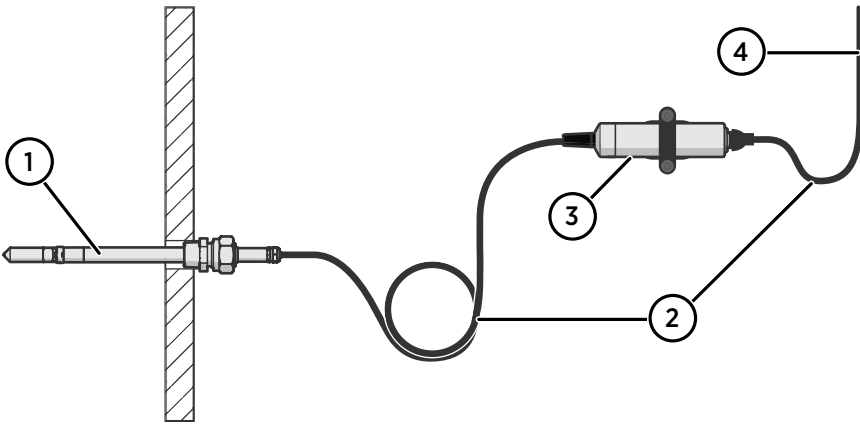

Figure 2 Example installation

- 1 Mount the probe head horizontally to prevent any water condensing on the probe head from running to the sensors.
- 2 Let the cable hang loosely to prevent condensed water from running along the cable to the probe body or probe head.
- 3 Attach the probe body to a wall or other surface using supplied probe holder (item code ASM213582).
- 4 Cable to Modbus master or Indigo device.

4.1 DMP5 probe

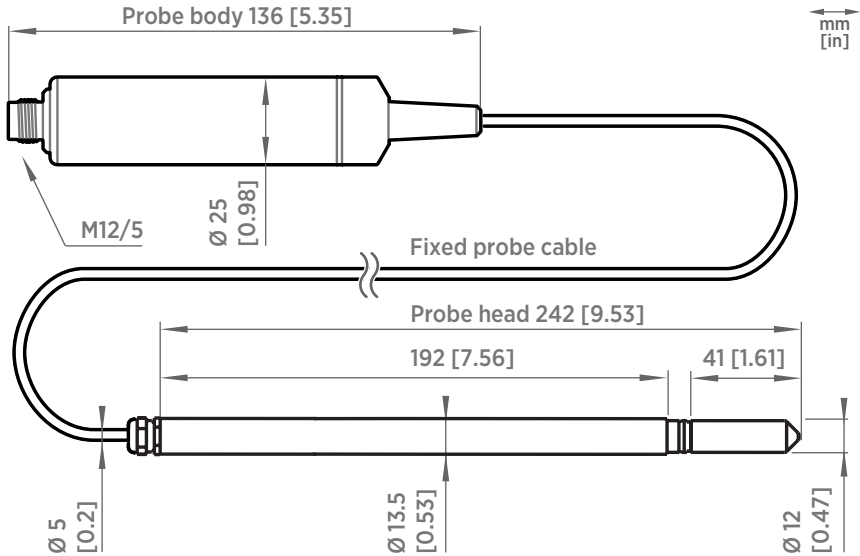

Figure 3 DMP5 dimensions

Vaisala DRYCAP® Dew Point and Temperature Probe DMP5 is designed for humidity measurement in applications with high temperatures. The long and robust steel probe and an optional installation flange allow easy installation with adjustable depth through insulation, for example, in ovens.

DMP5 is built for direct measurement in hot and dry processes, up to +180 °C (+356 °F). As the probe can be directly placed in the process, there is no need for a sampling system or trace heating. As a result, high measurement accuracy and constancy are maintained. DMP5 provides unmatched dry-end measurement accuracy at temperatures up to 140 °C; however, it can operate safely at temperatures up to 180 °C.

- Operating temperature of probe body -40 ... +80 °C (-40 ... +176 °F)
- Operating temperature of probe head -40 ... +180 °C (-40 ... +356 °F)

4.1.1 Installing with Mounting Flange 210696

Mounting Flange 210696 is designed for attaching Ø13.5 mm probe heads through the wall of a process chamber or duct. The flange kit includes a flange, a sealing ring, and screws.

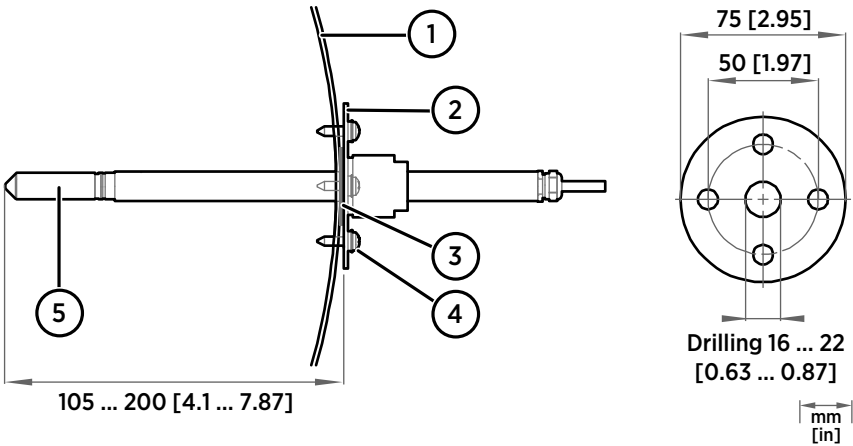

- 1 Wall of chamber or duct
- 2 Flange
- 3 Sealing ring
- 4 Self-tapping screws (B 4.2×16 DIN 7981)
- 5 Probe



When the temperature difference between the process or duct and the surroundings is large, insert the probe head as deep in the process or duct as possible. This prevents errors caused by heat conduction along the probe cable.

4.2 DMP6 probe

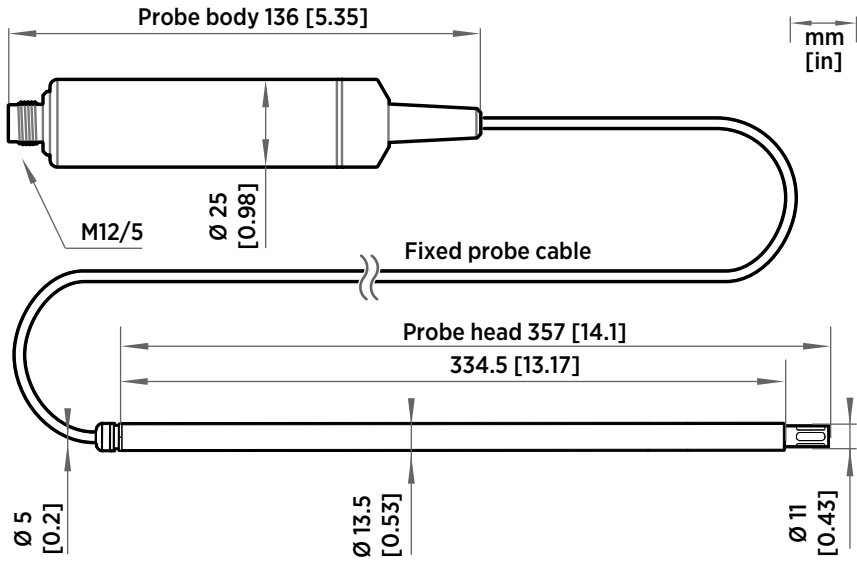

Figure 4 DMP6 probe dimensions

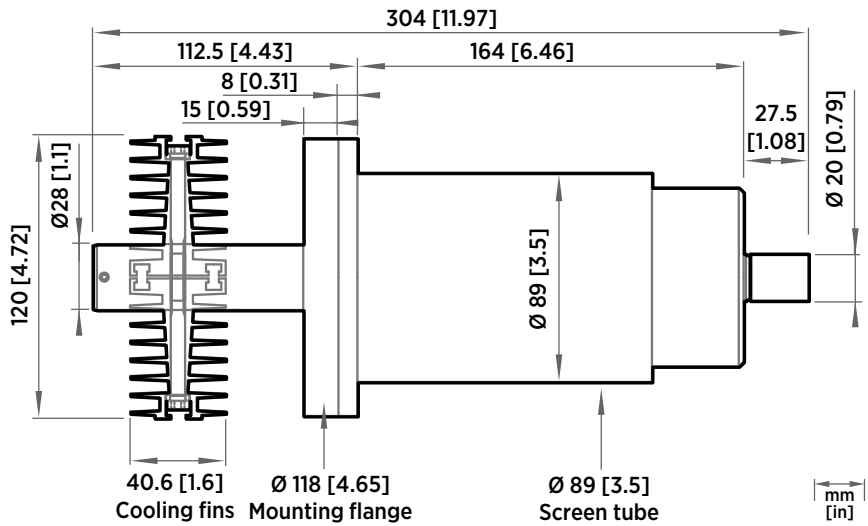

Figure 5 Cooling Set DMP246CS dimensions

Vaisala DRYCAP® Dew Point Probe DMP6 is designed for humidity measurement in industrial applications with very high temperatures. High temperature tolerance is achieved using a passive cooling set that conducts heat away from the probe and reduces temperature to optimal range for the sensor.

- Operating temperature of probe head 0 ... +350 °C (+32 ... +662 °F)
- Operating temperature of probe body -40 ... +80 °C (-40 ... +176 °F)

DMP6 is built for direct measurement in temperature range +100 ... +350 °C (+212 ... +662 °F). There is no need for a sampling system or trace heating. To tolerate these high temperatures, the probe head is inserted inside a cooling set that provides passive cooling. The cooling set has removable cooling fins that allow the operating temperature profile of the probe to be adjusted so that adequate cooling is provided for each application. The cooling system has no moving parts and requires no additional power or cooling utilities, so there is no risk of sensor damage due to mechanical cooling failure.

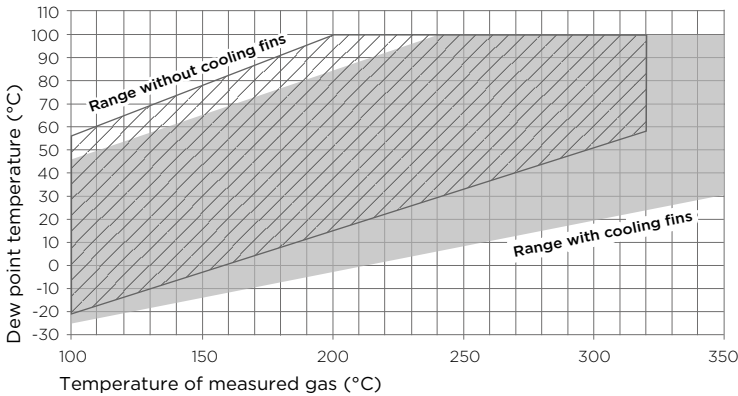

Figure 6 Operating range of DMP6 probe head



CAUTION! The operating range specifications apply in stand-still air. High flow rates in the process may reduce the probe performance and cause damage to the equipment.



Make sure that the upper limit of the dew point measurement range is not exceeded in low temperatures as this will lead to condensation.



You can read diagnostic measurement data from the probe using Insight software (**Diagnosics** page) or Modbus protocol (diagnostic data registers) and use it to verify your installation:

- **Sensor temperature** must never exceed +180 °C (+356 °F) even in exceptional process conditions.
- Allow the probe to stabilize after installation in the cooling set, and check the **Sensor saturation ratio**. If the value is below 20 %, install the cooling fins on the cooling set (unless already installed).

4.2.1 Installing probe head with Cooling Set DMP246CS



- Welding equipment
- Equipment for making a hole to the process wall
- 5-mm Allen key
- 2-mm Allen key

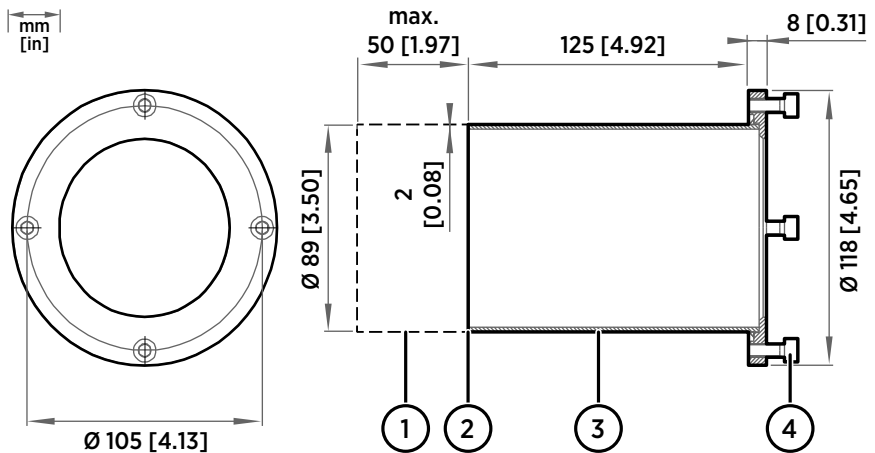

Figure 7 DMP246CS Cooling Set mounting flange

- 1 Lengthening piece for thick walls (not included)
- 2 Welding point
- 3 Mounting tube
- 4 Mounting screws (4 pcs, M6×16 DIN 912)

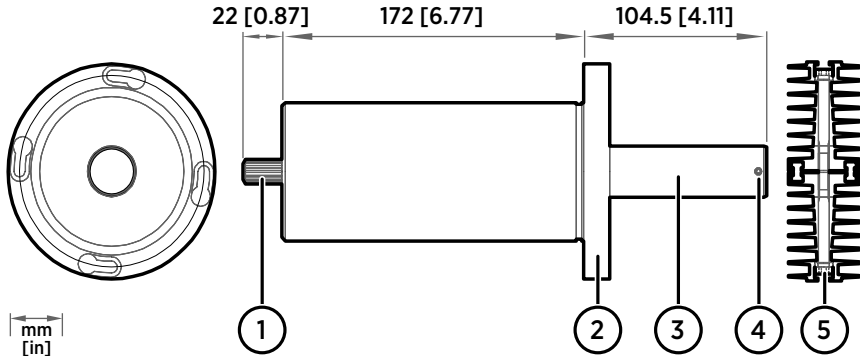

Figure 8 DMP246CS Cooling Set without mounting flange

- 1 Cooling bush
- 2 Flange
- 3 Cooling bar
- 4 Locking screws (4 pcs, M4×6 DIN 916)
- 5 Mounting screws of the cooling fins (M6×60 DIN 912)

- ▶ 1. Make a round $89.5 + 0.5$ mm ($3.52 + 0.02$ in) hole in the process wall. Install the cooling set horizontally whenever possible to ensure the best possible cooling performance.
2. If the process wall is more than 125 mm (4.92 in) thick, weld a lengthening piece (max. 50 mm (1.97 in)) to the mounting tube.
3. Weld the tube of the mounting flange tightly to the inner metal plate of the process wall.
4. Attach the cooling set to the mounting flange and use a 5-mm Allen key to tighten the mounting screws. Proper tightening of the mounting screws is important for good thermal contact.
5. If the process chamber is in use or otherwise warmer than ambient temperature, let the cooling set warm up before inserting the probe to avoid condensation:
 - a. Plug the hole of the cooling bar tightly with the plug that is attached to the cooling set.
 - b. If installation of the cooling fins is required, attach them at this point to let them warm up as well. See [step 9](#).
 - c. Wait for a few hours.
 - d. Unplug the cooling bar and continue the installation.
6. Use a 2-mm Allen key to loosen the locking screws on the cooling bar.

- Push the probe head into the cooling bar until it meets the other end and cannot be pushed farther. Approximately 7.5 cm (2.95 in) of the probe head will remain outside the cooling bar.



CAUTION! Do not push or pull from the probe cable.

- Tighten the locking screws to lock the probe head in place.
- If installation of cooling fins is required, attach them around the cooling bar using a 5-mm Allen key. Place the cooling fins so that the locking screws are not obstructed. Tighten the two mounting screws so that the fins have good thermal contact with the cooling bar.

4.2.2 Cooling Set installation example

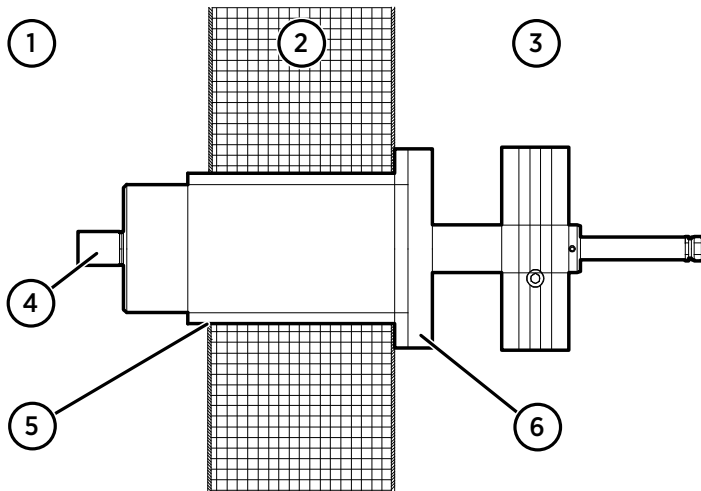

Figure 9 Example installation with Cooling Set DMP246CS

- Process chamber, maximum temperature +350 °C (+662 °F)
- Mineral wool or other insulation, total wall thickness is < 125 mm (4.92 in) so no lengthening piece is welded to mounting tube
- Space outside process chamber, in ambient temperature
- Location of dew point sensor when probe head is installed in the cooling set (under sintered filter)
- Tube of the mounting flange welded to inner plate of process wall
- Cooling set attached to mounting flange using mounting screws (4 pcs)

4.3 DMP7 probe

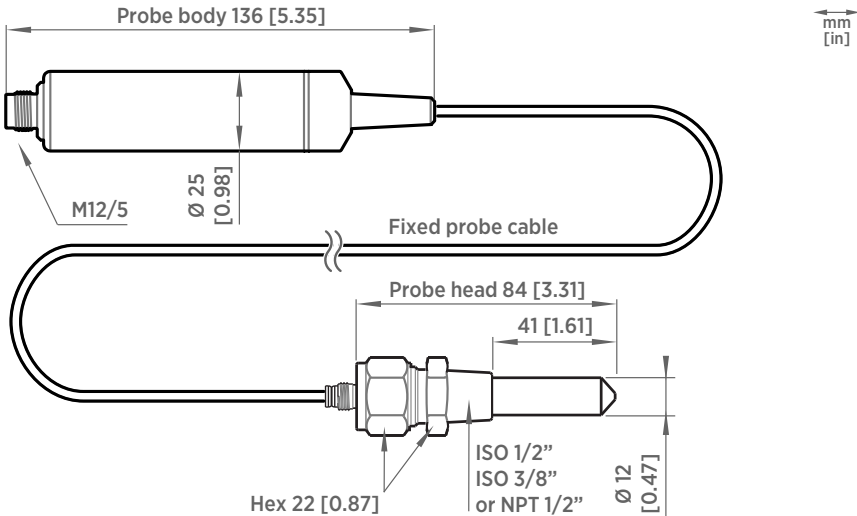

Figure 10 DMP7 dimensions

Vaisala DRYCAP® Dew Point and Temperature Probe DMP7 is designed for low-humidity applications. Thanks to its short probe length, it fits in installations with limited space, such as semiconductor manufacturing equipment. Other applications include industrial drying, compressed air systems, dry rooms, and blanket gases in metal heat treatment.

- Operating temperature of probe head $-40 \dots +80 \text{ }^{\circ}\text{C}$ ($-40 \dots +176 \text{ }^{\circ}\text{F}$)
- Operating temperature of probe body $-40 \dots +80 \text{ }^{\circ}\text{C}$ ($-40 \dots +176 \text{ }^{\circ}\text{F}$)
- Operating pressure of probe head $0 \dots 10 \text{ bar}$ ($0 \dots 145 \text{ psia}$)



When installed in a process with a pressure differing from normal atmospheric pressure, input the correct pressure into the pressure compensation setpoint parameter or register of the probe. This allows the probe to apply the appropriate pressure compensation into its measurement results.

4.3.1 Pressure-tight Swagelok installation kit

Swagelok installation kit (Vaisala items SWG12ISO12, SWG12ISO38, and SWG12NPT12) is an optional accessory which includes a pressure-tight Swagelok® connector with ISO1/2", ISO3/8" or NPT1/2" thread.

For instructions on how to tighten the Swagelok connector properly, see the installation instructions provided with the installation kit, [SWG12ISO12 Swagelok® Connector Assembly Drawing \(DRW218087\)](#).



CAUTION! Note that overtightening the connector may damage the probe head.

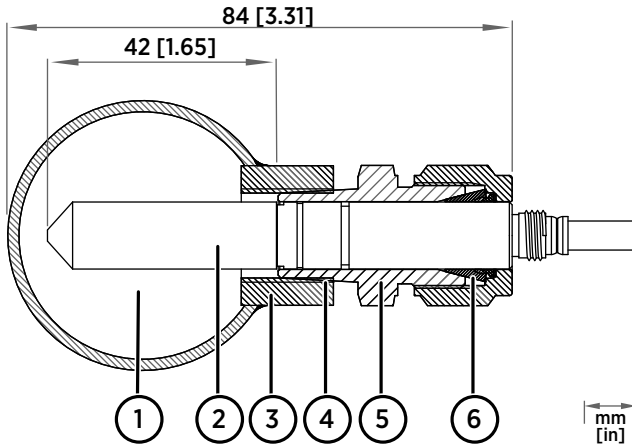

Figure 11 DMP7 installation to pipeline using a Swagelok installation kit

- 1 Max. process pressure 10 bar (145 psi), max temperature +80 °C (+176 °F)
- 2 Probe head
- 3 Duct connector
- 4 ISO1/2", ISO3/8" or NPT1/2" thread
- 5 Swagelok connector
- 6 Ferrules

4.4 DMP8 probe

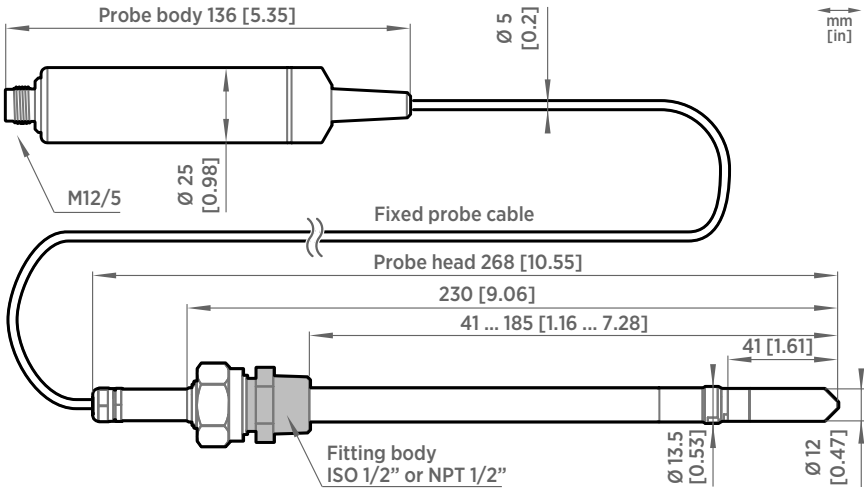

Figure 12 DMP8 dimensions

Vaisala DRYCAP® Dew Point and Temperature Probe DMP8 is designed for industrial low-humidity applications such as industrial drying, compressed air systems, and semiconductor industry. It can be installed in a 1/2" NPT or ISO thread with adjustable insertion depth.

- Operating temperature of probe head -40 ... +80 °C (-40 ... +176 °F)
- Operating temperature of probe body -40 ... +80 °C (-40 ... +176 °F)
- Operating pressure of probe head 0 ... 4 MPa (0 ... 40 bar)

An optional ball valve kit allows for inserting or detaching the probe from a pressurized line.

For more information on using the probe with the ball valve, see [Ball Valve Kit \(BALLVALVE-1\) Installation Guide \(M212837EN\)](#).

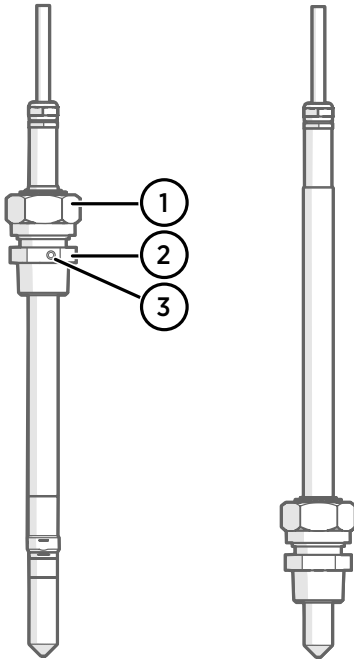

Figure 13 DMP8 probe head

- 1 Clasp nut, 24 mm hex nut
- 2 Fitting body, 27 mm hex head
- 3 Leak screw (on ISO 1/2" fitting body HM47432 only)



Fitting body with a leak screw can be useful when the probe head cannot be installed directly in the pressurized process or process pipe. The leak screw allows a small sample flow to escape from the process out to atmospheric pressure, enabling a fast response time although the probe is not installed in the process.

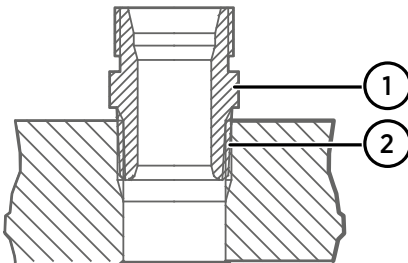

Figure 14 Sealing of fitting body into process

- 1 Fitting body with 24 mm hex nut and tapered thread
- 2 Seal with a suitable thread sealant. For example, LOCTITE® No. 542 with activator No. 7649, MEGA-PIPE EXTRA No. 7188, or PTFE tape.



Follow the instructions of the sealant manufacturer. PTFE tape does not lock the parts together. Use two fork wrenches (24 mm and 27 mm) when tightening and opening the clasp nut of the probe.

4.4.1 Tightening the clasp nut

- ▶ 1. Adjust the probe to a suitable depth according to the type of installation.
2. Tighten the clasp nut to finger tightness.
3. Draw a line on the fitting screw and the clasp nut to mark their position.
4. Tighten the nut a further 50 ... 60° (1/6 turn) with a wrench. If you have a suitable torque wrench, tighten the nut to max 45 ±5 Nm (33 ±4 ft-lbs).

Do not overtighten the clasp nut.



CAUTION! Take care not to damage the probe body. A damaged body makes the probe less tight and may prevent it from going through the clasp nut.



CAUTION! In pressurized processes it is essential to tighten the supporting nuts and screws very carefully to prevent loosening of the probe by the action of pressure.



When installed in a process with a pressure differing from normal atmospheric pressure, input the correct pressure into the pressure compensation setpoint parameter or register of the probe. This allows the probe to apply the appropriate pressure compensation into its measurement results.

4.4.2 DMT242SC sampling cell

DMT242SC is a basic sampling cell with only the main sampling cell body. The inlet and outlet are female threaded sample connectors (inlet G3/8", outlet G1/4" ISO).

DMT242SC is suitable for users requiring only a sampling cell to fit the measurement into and doing further assembly (piping into inlet and outlet, valves, possible flow meter) by themselves.

4.4.3 DMT242SC2 sampling cell with Swagelok connectors

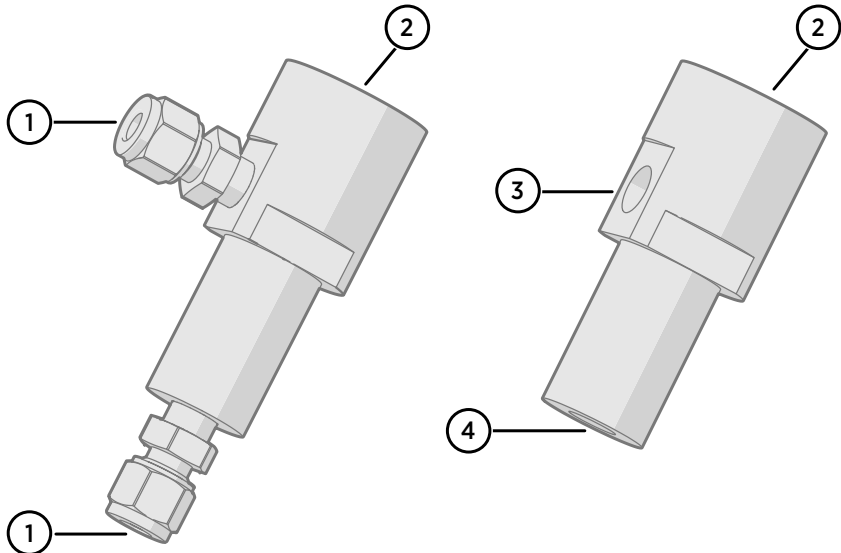

Figure 15 Sampling cells DMT242SC2 (left) and DMT242SC (right)

- 1 Male pipe welded connector Swagelok 1/4"
- 2 G1/2"
- 3 G1/4"
- 4 G3/8"

DMT242SC2 is similar to DMT242SC, but connections are made easy. The sampling cell includes welded Swagelok connectors at both the inlet and outlet that fit directly to 1/4" tubing.

To fit 6 mm tubing to the connectors, an adapter such as Swagelok® Reducer SS-6M0-R-4 (not supplied by Vaisala) can be used.

DMT242SC2 is the suitable choice in, for example, plastics drying systems, where the measurement is made by tapping off the dryer system and bringing a small air stream to the sensor.

The Swagelok connectors of DMT242SC2 connect easily to a cooling coil or tubing, providing the essential function of cooling the dry air to ambient temperature before it reaches the sensor.

4.5 Wiring

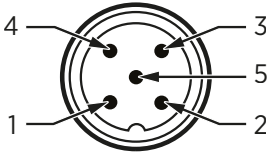

Figure 16 M12 5-pin A-coded male connector pinout

Pin #	Function	Notes	Wire colors in Vaisala cables
1	Power supply	Operating voltage: 15 ... 30 V DC Current consumption: 10 mA typical, 500 mA max.	Brown
2	RS-485 -		White
3	Power GND and RS-485 common		Blue
4	RS-485 +		Black
5	Not connected		Gray

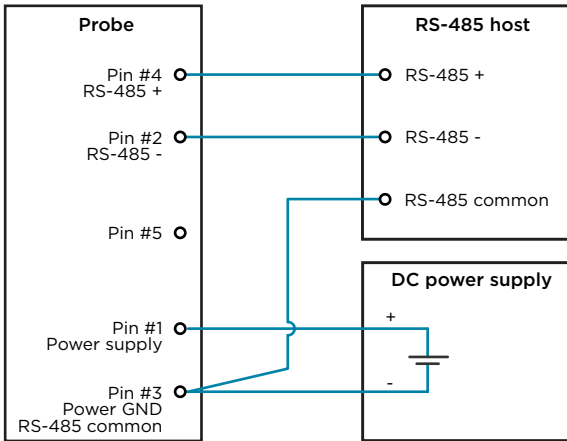

Figure 17 RS-485 wiring



Recommended maximum length of the RS-485 line is 30 m (98 ft).

4.6 Configuring environmental compensations

After installation, configure the pressure compensation setting, if relevant to your probe and its measurement environment.

For example, when you have installed the probe in a process with a pressure differing from normal atmospheric pressure, update the correct pressure into the pressure compensation setpoint parameter or register of the probe. This allows the probe to apply the appropriate pressure compensation into its measurement results.

You can configure the setting with the Insight software or the Indigo80 handheld indicator, or using the Modbus protocol.

More information

- [Environmental compensation \(page 20\)](#)
- [Configuring environment settings with Indigo80 handheld indicator \(page 51\)](#)

5. Configuration with Insight software

5.1 Vaisala Insight software

Vaisala Insight software is a configuration software for Indigo-compatible devices. With the Insight software, you can:

- See probe information and status
- See real-time measurement
- Record data up to 48 hours and export in CSV format
- Configure probe features such as measurement filtering, sensor purge, and serial communication
- Update probe calibration information:
 - Calibration date and text
 - Calibration interval and expiry date
 - Enable or disable calibration reminder function



Adjustment of measurement is not available in Insight software for DMP Series probes. If adjustment is necessary, contact Vaisala. See [Maintenance and calibration services \(page 89\)](#).

Microsoft Windows® operating system and Indigo USB adapter (item code USB2) or Vaisala USB cable (item code 242659) required.

Download Vaisala Insight software at www.vaisala.com/insight.

5.2 Connecting to Insight software



- Computer with a Microsoft Windows® operating system (64-bit version) and Vaisala Insight PC software installed
- Indigo USB adapter (item code USB2) or USB connection cable (item code 242659)



CAUTION! When connecting several devices at the same time, note that your computer may not be able to supply enough power through its USB ports. Use an externally powered USB hub that can supply >2 W for each port.

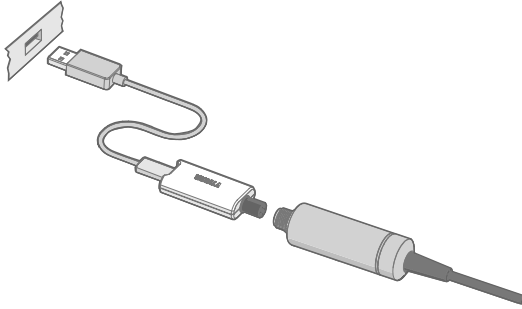



Figure 18 Connecting probe to Insight using Indigo USB adapter

- ▶ 1. Open the Insight software on your PC.
2. Verify the current operating mode of Insight from the **Settings** menu and change it if appropriate:
 - **Basic mode** is suitable for most use cases.
 - **Advanced mode** provides access to additional configuration options. Use **Advanced mode** only when instructed to do so by product documentation or Vaisala technical support.
3. Connect the USB adapter to a free USB port on the PC or USB hub.
4. Connect the probe to the USB adapter.
5. Wait for the Insight software to detect the probe.

5.3 Configuration options

Select  > **Configure device** to access configuration options in Insight software.

Available configuration options include all of the Modbus configuration registers and several additional options. Insight software is the recommended way to change the probe configuration.



You can restore the probe back to its default settings using the **Factory default settings > Restore settings** function. Doing this will also revert the latest entered calibration information to the information that was stored with the factory calibration.

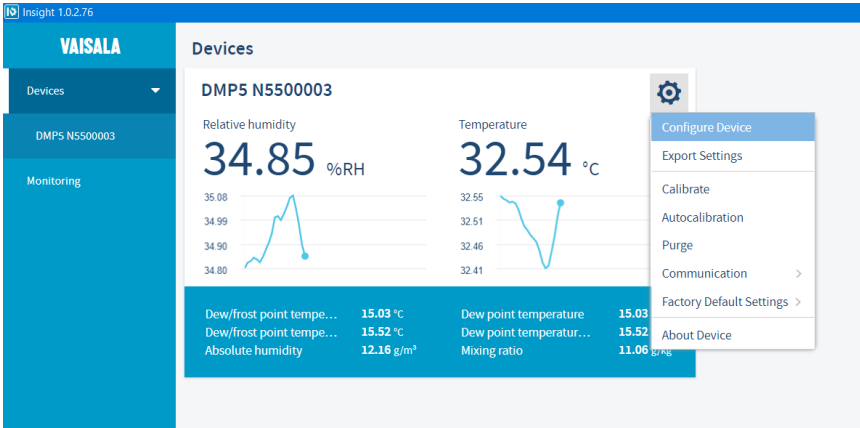

Figure 19 DMP5 in Insight software

More information

- [Configuration registers \(page 79\)](#)

5.4 Diagnostics in Insight

Messages sent by the connected devices are shown automatically in Insight. Additional diagnostic data is available on the **Diagnostics** page. The data available depends on the probe model and Insight operating mode (basic or advanced). The data can be very useful when diagnosing issues together with Vaisala support, particularly the diagnostic files.

Diagnostic files

If Insight is in **Advanced mode**, you can retrieve the following diagnostic files from the connected probe:

- **SSR/T histogram:** Table of humidity and temperature conditions measured by the probe
- **Error log:** Cumulative total of the error and status events tracked by the probe

Both files contain data from since the probe was manufactured, or since the files were last cleared. Clearing the files is not recommended unless instructed by Vaisala support. The buttons to clear the files are located at the bottom of the **Diagnostics** page.

The files are in comma separated value (CSV) format. They can be opened for viewing in spreadsheet programs such as Microsoft Excel or in text editors.

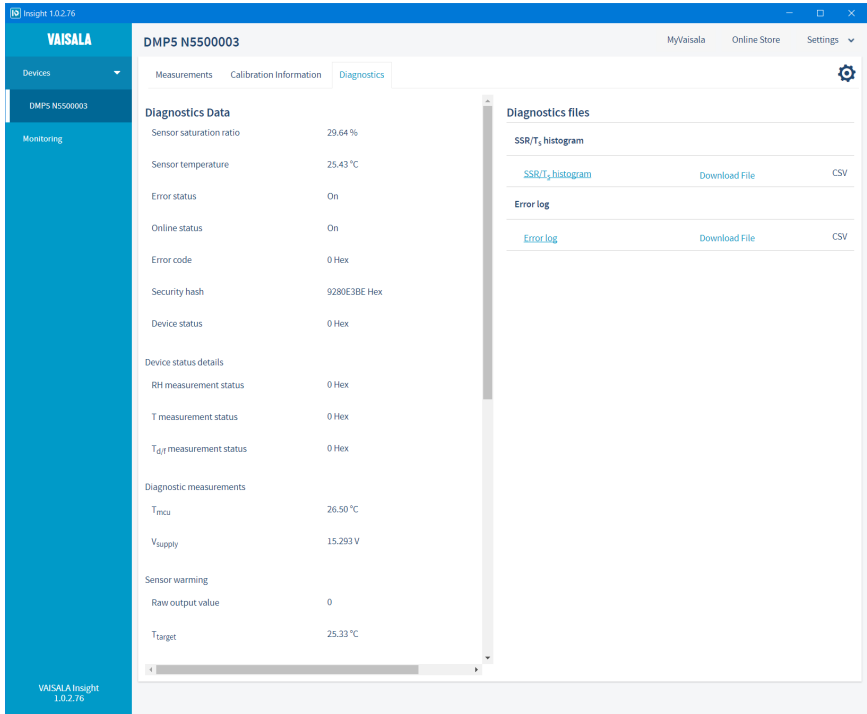

Figure 20 DMP5 diagnostics in Insight (advanced mode)

6. Using probe with Indigo transmitters

Indigo transmitters are host devices that extend the feature set of connected probes with a range of additional options for outputs, configuration access, measurement viewing, and status monitoring.

Available features vary depending on the transmitter model. Models without display use a LED indicator for notifications.

For more information on the features of the different Indigo transmitter models, see www.vaisala.com/indigo.

For instructions on installing and configuring Indigo transmitters, see the applicable Indigo transmitter user documentation available at the Vaisala documentation portal docs.vaisala.com.

6.1 Connecting probe to Indigo200 series transmitters

Indigo200 series transmitters have a probe connector where compatible probes can be attached directly. A cable may also be used to connect the probe. Cables are available to order at store.vaisala.com.



CAUTION! The IP classification of probes is valid only when the probes are connected to the probe connection cable, or to the cable connector inside the locking wheel of the transmitter.

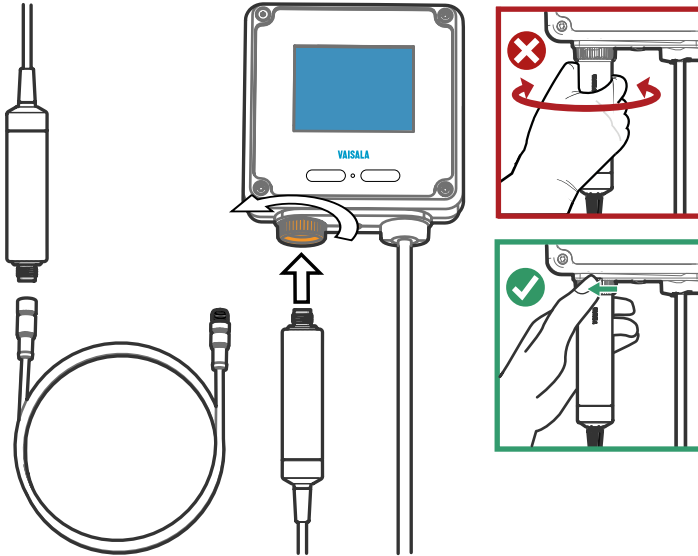

Figure 21 Connecting probe to Indigo200 series transmitter

- ▶ 1. Insert the probe or the cable into the transmitter's connector. Using a cable is recommended for strain relief.
- 2. Turn the locking wheel of the transmitter to lock the probe or cable in place. **Do not turn the probe or the cable itself**, as that will damage the connectors.
- 3. If you are using a cable, connect the probe to the cable.
- 4. When the transmitter recognizes the connected probe, it shows a notification message on the display.

6.2 Connecting probe to Indigo300 transmitter

Indigo300 transmitters have a probe connector where compatible probes can be attached directly. A cable may also be used to connect the probe. Cables are available to order at store.vaisala.com.



CAUTION! The IP classification of probes is valid only when the probes are connected to the probe connection cable, or to the cable connector inside the locking wheel of the transmitter.

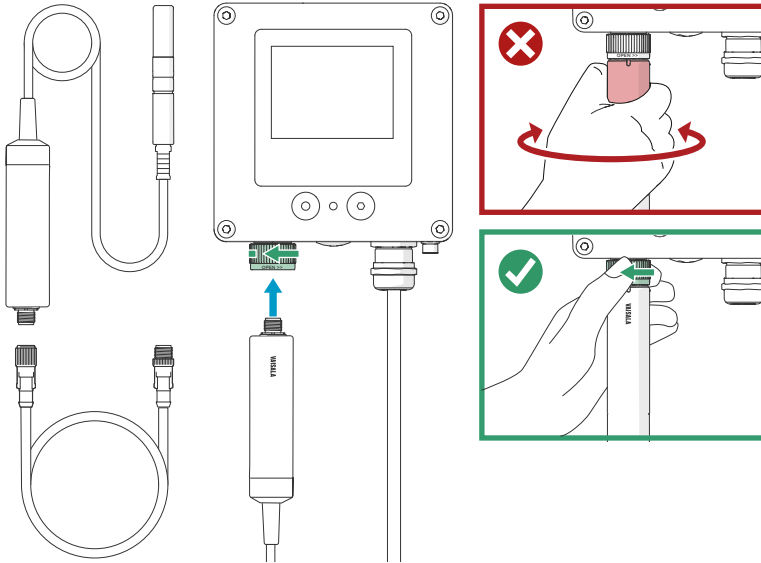

Figure 22 Connecting probe to Indigo300 transmitter

- ▶ 1. Insert the probe or the cable into the transmitter's connector.
- 2. Turn the locking wheel of the transmitter to lock the probe or cable in place. **Do not turn the probe or the cable itself**, as that will damage the connectors.
- 3. If you are using a cable, connect the probe to the cable.
- 4. When the transmitter recognizes the connected probe, it shows a notification message on the display.

6.3 Connecting probes to Indigo500 series transmitters



CAUTION! The IP classification of probes is valid only when the probes are connected to the probe connection cable.



If your transmitter was delivered with preconfigured analog outputs, make sure that you connect the measurement devices accordingly. See the label inside the transmitter enclosure for the correct order of the measurement devices.

Probes are connected to Indigo500 series transmitters using a cable. Connections are made to the screw terminals inside the housing. The Indigo520 model allows 2 probes to be connected. After connecting a probe, use the touchscreen interface or the web user interface to configure the transmitter.

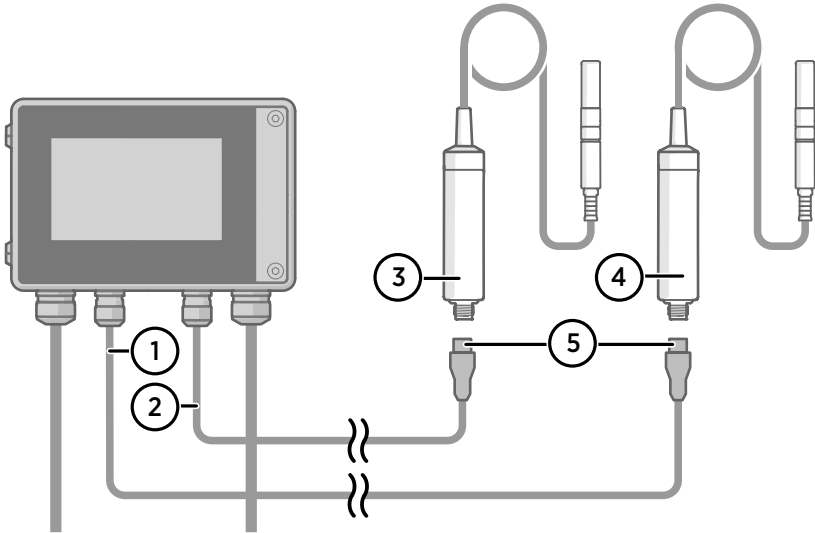

Figure 23 Connecting probes to Indigo500 transmitter

- 1 Probe connection cable for probe 1
- 2 Probe connection cable for probe 2
- 3 Probe to be connected as probe 2
- 4 Probe to be connected as probe 1
- 5 Probe cable connector (5-pin M12)

7. Using probe with Indigo80 handheld indicator

7.1 Indigo80 handheld indicator

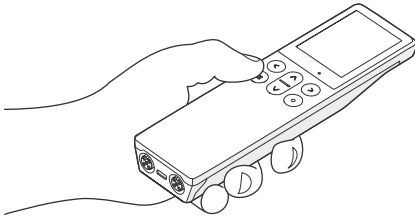

Figure 24 Indigo80 handheld indicator

Vaisala Indigo80 Handheld Indicator is a portable diagnostics tool that accommodates up to two Vaisala Indigo-compatible probes or transmitters for measuring a wide range of parameters.

With the indicator, you can:

- See real-time measurements and device and status information
- Log measurement data
- Update probe calibration information
- Configure probe features and settings such as condensation prevention, compensation setpoints, sensor purge, filtering factor, and serial communication. The available features and settings depend on the probe model and firmware version.



Accessing certain configuration options for your probe requires using the free Insight PC software, downloadable at www.vaisala.com/insight.

The help tours in the indicator's user interface guide you through the key features of the indicator. You can access the tours in the **Help** menu by pressing the  button.

For more information on using the indicator, for example, editing the measurement views and performing data logging, see [Indigo80 User Guide \(M212722EN\)](#).

More information

- [Configuring probe features with Indigo80 handheld indicator \(page 49\)](#)
- [Configuring environment settings with Indigo80 handheld indicator \(page 51\)](#)

7.1.1 Probe compatibility

The Indigo80 handheld indicator is tested for compatibility with probes that have firmware version 1.2.5 or newer.

Probes with older firmware versions may have limited compatibility with the indicator.

For the most up-to-date version compatibility information, see [Indigo80-compatible Firmware Technical Note \(M212901EN\)](#).

7.1.2 Indigo80 keypad

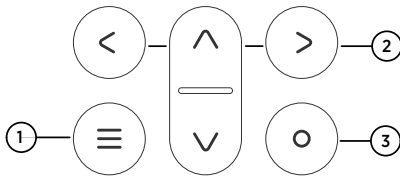

Figure 25 Indigo80 keypad

- 1 Power on/off and main menu button
- 2 Arrow buttons for navigating menus and scrolling views
- 3 Select button for selecting items in the user interface

7.1.3 Indigo80 main menu

Pressing the  button while navigating the Indigo80 menus and views opens the main menu.

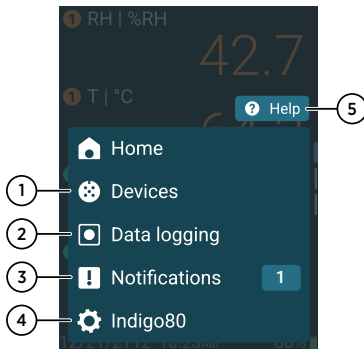

Figure 26 Indigo80 main menu

- 1 **Devices** menu contains, for example, options related to sensor purge, calibration, and environment settings (depending on the connected device).
- 2 **Data logging** menu for setting logging interval and duration, and browsing data files.
- 3 **Notifications** menu displays notifications related to Indigo80 and the connected devices.
- 4 **Indigo80** menu for changing the settings of Indigo80 (for example, date, time, and language) and viewing device information.
- 5 **Help** menu contains a **Getting started** tour showing the key features of Indigo80, as well as instructions for sending devices to Vaisala for calibration and maintenance.

7.2 Connecting probes to Indigo80



- Probe connection cable

Up to two Vaisala Indigo-compatible probes or transmitters can be connected to the ports located on the bottom of Indigo80. You can connect and disconnect devices both when the indicator is powered on and when it is off.

Vaisala recommends using cables provided by Vaisala when connecting devices to the indicator. Cables and other accessories are available to order at store.vaisala.com.

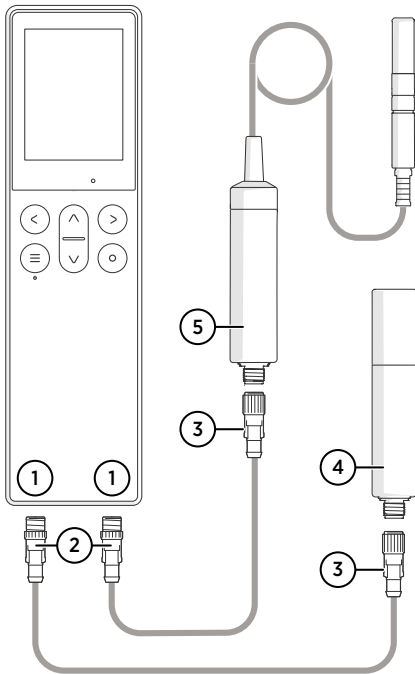

Figure 27 Connecting probes to Indigo80

- 1 M12-5F ports on the bottom of Indigo80 for connecting compatible Vaisala devices. Ports are labeled 1 and 2.
- 2 M12-5M A-coded cable connector
- 3 M12-5F A-coded cable connector
- 4 Probe displayed as 1 by Indigo80 (GMP252 shown)
- 5 Probe displayed as 2 by Indigo80 (HMP7 shown)

- ▶ 1. If the indicator is powered and no devices are connected to it, the text **Please connect a probe** will be shown on the display.

2. Insert the probe connection cable in one of the ports on the bottom of the indicator.

- **Note the orientation of the cable connector when inserting it**
- **Hold the connector in place while turning its locking ring clockwise – never twist the connector body!**

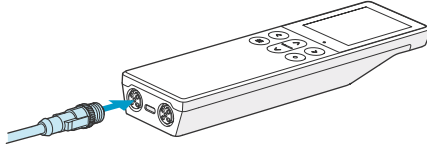
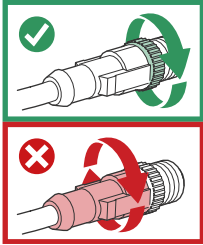

3. Connect the probe to the M12-5F end of the probe connection cable.

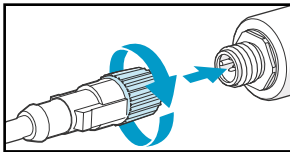

When the indicator recognizes the connected probe, it shows a notification on the display (for example, **GMP252 connected**). A probe connected to the leftmost port in the indicator is labeled **1** on the indicator's display, while the probe in the rightmost port is labeled **2**.

4. To change probes, simply detach the cable from the probe and connect a new probe.

7.3 Configuring probe features with Indigo80 handheld indicator





- Probe connection cable

You can use the Indigo80 handheld indicator to configure probe features such as compensation setpoints, filtering factor, and serial communication. The available features depend on the probe model and firmware version.



Accessing certain configuration options for your probe requires using the free Insight PC software, downloadable at www.vaisala.com/insight.

- ▶ 1. Connect the probe(s) to the indicator.
2. Open the main menu by pressing .
3. Select **Devices**. If you have more than one device connected to the indicator, make a further selection between the devices.
4. Select **Settings** to access and change the features available for your probe.
5. Exit the menu by pressing  or return to the main menu by pressing .

More information

- ▶ [Sensor purge \(page 19\)](#)
- ▶ [Environmental compensation \(page 20\)](#)
- ▶ [Filtering factor \(page 21\)](#)

7.3.1 Example of configuring filtering factor with Indigo80 handheld indicator





- Probe connection cable

The filtering factor allows averaging the output if the measuring environment produces occasional exceptionally high or low readings.

This example shows how to configure the filtering factor as **0.9** using the Indigo80 handheld indicator.

This means that the new measurement output is a combination of the latest measurement (90 %) and the previous measurement (10 %).

- ▶ 1. Connect the probe(s) to the indicator.
2. Open the main menu by pressing .
3. Select **Devices**. If you have more than one device connected to the indicator, make a further selection between the devices.
4. Select **Settings > Filtering**.
5. Select **Filtering factor**.
 - a. Use the arrow buttons to set the value as **0.9**.
 - b. Select **Set**.

6. Select **Extended filtering on/off > On** to enable measurement filtering using the filtering factor defined in the previous step.
7. Exit the menu by pressing  or return to the main menu by pressing .

More information

- [Filtering factor \(page 21\)](#)

7.4 Configuring environment settings with Indigo80 handheld indicator



- Probe connection cable

For optimal measurement accuracy, you can use the Indigo80 handheld indicator to give additional information about the connected probe's measurement environment.



The environment settings available via Indigo80 correspond to the environmental compensation settings of the probe. Therefore, **Environment settings** and **Settings > Compensation setpoints** are interconnected: the configuration set in either menu is applied to both.

- ▶ 1. Connect the probe(s) to the indicator.
2. Open the main menu by pressing .
3. Select **Devices**. If you have more than one device connected to the indicator, make a further selection between the devices.

4. Select **Environment settings** to access the settings for your probe.

The available environment settings depend on the probe and probe firmware version.

Pressure

Value for pressure compensation. The current value is stored in non-volatile memory when the device is turned off, and restored at power-up.

Temperature



If any value is entered in this field, the device will use it as its temperature measurement value instead of its own sensor reading. This is needed when probe heating is used, as it will also heat the temperature sensor of the device. At device reset, the value is cleared.



The temperature value needs an external source, for example, another probe that is able to provide the value constantly in real time, and the value needs to correspond to the temperature of the measurement environment as accurately as possible. Thus, set the temperature value only if you have another probe connected to the indicator from which you can read the value. Do not set the temperature value manually.



5. Select a setting from the list, for example, **Pressure**.

- a. Select the unit, if prompted.
- b. Use the arrow buttons to set the desired value, and then select **OK** or **Set**.

You can also select to read the value from another probe connected to the indicator, provided that the probe can output the required compensation parameter. Press  to highlight the **Read value from** field, and then press  to select the other probe as the source of the value.



For **Temperature**, always set the temperature value to be read from another probe. Do not set the temperature value manually. Make sure that both probes are in the same environment to get the most accurate measurement values.

6. Exit the menu by pressing  or return to the main menu by pressing .

More information

- [Environmental compensation \(page 20\)](#)

8. Maintenance

8.1 Cleaning the probe



CAUTION! Do not attempt to clean the sensors under the filter.



Do not spray anything directly on the probe head, since that may deposit impurities on the sensors.

You can clean the probe, probe body, and cable by wiping them with a soft, lint-free cloth moistened with water or a suitable cleaning agent, such as isopropyl alcohol. Do not wipe the filter: wiping the filter may block its pores and/or deposit residue on the filter. If the filter is heavily contaminated, replace it.

When cleaning, follow these precautions:

- Avoid touching the filter. If you need to touch the filter, always wear clean gloves (cotton, rubber or similar material). Keep the filter free of any grease or oil.
- Do not scrape the probe or the probe body.
- Do not immerse the probe or the probe body in liquid to clean them.
- Wipe cleaning agents off the probe, probe body, and the cable after cleaning.

8.2 Changing the probe filter



- New compatible filter
- Clean lint-free gloves



CAUTION! Sensors are easily damaged when the filter is not in place. Handle the probe head carefully.

- ▶ 1. Put on clean gloves before touching the filter.
2. Turn the filter counter-clockwise to loosen it.
3. Remove the filter from the probe head. Be careful not to touch the sensors with the filter.
4. Install a new filter on the probe head. Tighten the filter properly (recommended force 5 Nm).

8.3 Calibration and adjustment



Calibration means comparing the measurement output of the device to a known reference, such as a known environment in a calibration chamber or the output of a reference instrument. Correcting the reading of the device so that it measures accurately is referred to as **adjustment**.

The probe is fully calibrated and adjusted as shipped from the factory. To maintain the accuracy of the measurement, calibrate and adjust the probe as needed. Typical calibration interval is one year, but depending on the application it may be necessary to check the accuracy more frequently.

When adjustment is necessary, have Vaisala calibrate and adjust the probe.

Factory calibration leads to highest accuracy and lowest uncertainty. After factory calibration the instrument performs as new. For up-to-date information about calibration points and offering, visit store.vaisala.com.



WARNING! When returning a product for calibration or repair, make sure it has not been exposed to dangerous contamination, and is safe to handle without special precautions.



If you think the device is not measuring correctly, calibration and adjustment is not the first thing to do. Check the following first:

- Make sure nothing is interfering with the measurement: heat sources, temperature differences, or condensation.
- Check that there is no moisture on the probe. If the sensor has become wet, wait for it to dry.
- Always wait for the measurement to stabilize.

9. Troubleshooting

9.1 Problem situations

Table 5 Troubleshooting table

Problem	Possible cause	Solution
Measurement output seems incorrect	Installation location is not representative of actual conditions you want to measure	Verify the installation location and reinstall or relocate the probe if necessary.
	Heat conduction along probe head and cable is interfering with measurement accuracy	Follow the installation recommendations for cases when temperature of measured environment differs greatly from ambient. See Installation (page 22) .
	Probe is in need of adjustment	Have the probe adjusted by Vaisala. See Calibration and adjustment (page 54) .
Probe status indicator LED is red	Probe is in error state	Connect the probe to Insight software or an Indigo transmitter and read the error message(s). See Vaisala Insight software (page 38) and Error messages (page 55) .
Values of measurement parameters stop changing for a few minutes	Probe is performing a sensor heating function such as sensor purge or waiting for the sensor to cool down	Wait for the function to complete and measurement parameters to be available again.

9.2 Error messages

Probes can communicate with error messages when they are connected to an Indigo transmitter or Insight software. The messages are categorized according to the severity of the status:

- **Critical errors** are fatal to the operation of the device. It may not be able to respond to communication at all, and will not measure correctly.
- **Errors** prevent normal operation of the device. Depending on the problem, errors may resolve themselves. For example, a completely wet humidity sensor may cause a humidity measurement error.
- **Warnings** do not prevent normal operation but may indicate possible problems.
- **Status** indicates a known state of the device.

Error message	Description	Recommended action
Critical errors		
Firmware checksum mismatch [49]	The installed firmware is corrupted.	Contact Vaisala technical support.
Device settings corrupted [50]	Parameter memory is corrupted.	
Additional configuration settings corrupted [51]		
Sensor coefficients corrupted [52]		
Main configuration settings corrupted [53]		
Factory default settings corrupted [54]		
Non-volatile memory read write failure [57]	Hardware fault.	
Errors		
Temperature measurement error [44]	Readings from sensor(s) are missing or out of range.	Inspect probe head and sensors visually. If the probe is completely wet, allow it to dry out. If the sensors are damaged or missing and the error message(s) stay active, contact Vaisala to have the probe repaired.
Humidity measurement error [45]		
Humidity sensor failure [46]		
Capacitance reference error [47]	Hardware fault.	Contact Vaisala technical support.
Sensor heater error [212]		
General device failure [994]	High number of measurement errors, capacitance reference errors, or sensor heater errors written in the error log.	
Ambient temperature out of range [48]	Probe body is too hot or cold.	Relocate the probe body so that its ambient temperature is within the specified operating range.
Supply voltage out of range [55]	Probe supply voltage is too high or low.	Check and correct the supply voltage.

Warnings		
Autocalibration failed	Measurement environment is not suitable for autocalibration.	Autocalibration can only be performed successfully in dry and stable conditions. This warning is expected if the probe head is in normal room humidity. Occasional autocalibration failures are not a cause for concern as long as autocalibration is usually successful.
Calibration certificate checksum mismatch [58]	Certificate stored in the probe has an invalid checksum.	Contact Vaisala technical support
Calibration has expired [353]	This warning is displayed by the calibration reminder functionality if the calibration interval has been exceeded.	Calibrate the probe and update the calibration date information.
Software restart [679]	The probe has automatically restarted itself.	Check that supply voltage is stable and operating environment is within specification.
Unexpected device restart [216]		
Status messages		
Calibration is about to expire [352]	This message is displayed by the calibration reminder functionality.	Calibrate the probe and update the calibration date information.
Purge in progress [287]	Sensor purge of the humidity sensor is ongoing.	Wait for sensor purge to complete.
The readings stay frozen until the sensor cools down [288]	Probe is waiting for its sensors to cool down.	Wait for measurement readings to become available.

9.3 Restoring factory default settings with Insight software

If needed, you can restore the probe back to its factory default settings using the Insight software. Doing this will also clear any user adjustment and restore the latest adjustment performed by Vaisala.

- ▶ 1. Connect the probe to the Insight software.
2. Select  > **Factory default settings** > **Restore settings**.
3. Wait for the probe to be re-detected.

More information

- [Connecting to Insight software \(page 38\)](#)

9.4 Restoring factory default settings with Indigo80 handheld indicator



- Probe connection cable

If needed, you can restore the probe back to its factory default settings using the Indigo80 handheld indicator. The user adjustment of the probe and the settings or log files of the indicator itself are not affected.

- ▶ 1. Connect the probe(s) to the indicator.
2. Open the main menu by pressing ⊖.
3. Select **Devices**. If you have more than one device connected to the indicator, make a further selection between the devices.
4. Select **Factory default settings > Restore settings > OK**.
5. Confirm by selecting **OK**.
6. Exit the menu by pressing ⊙ or return to the main menu by pressing ⊖.

More information

- [Connecting probes to Indigo80 \(page 48\)](#)

10. Technical data

10.1 DMP5 specifications

Table 6 DMP5 measurement performance

Property	Description/Value
Dew point	
Sensor	DRYCAP® 180S
Measurement range	-40 ... +100 °C (-40 ... +212 °F) T _{d/f}
Accuracy	±2 °C (±3.6 °F) T _{d/f} See accuracy graph
Response time 63 % [90 %] ¹⁾	
From dry to wet	5 s [10 s]
From wet to dry	45 s [5 min]
Temperature	
Measurement range	0 ... +180 °C (+32 ... +356 °F)
Accuracy at +100 °C (+212 °F)	±0.4 °C (±0.72 °F)
Temperature sensor	Pt100 RTD Class F0.1 IEC 60751
Mixing ratio	
Measurement range (typical)	0 ... 1000 g/kg (0 ... 7000 gr/lbs)
Accuracy (typical)	±12 % of reading
Absolute humidity	
Measurement range	0 ... 600 g/m ³
Accuracy	±10 % of reading (typical)

1) Tested with sintered filter.

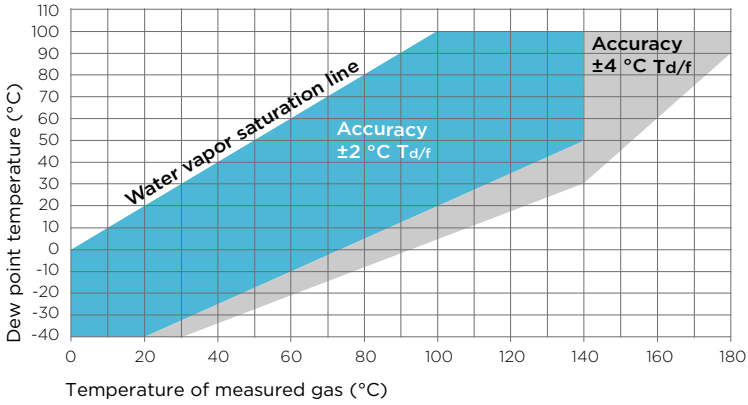

Figure 28 DMP5 dew point accuracy vs. measurement conditions

Table 7 DMP5 operating environment

Property	Description/Value
Operating temperature range for probe head	-40 ... +180 °C (-40 ... +356 °F)
Operating temperature range for probe body	-40 ... +80 °C (-40 ... +176 °F)
Storage temperature	-40 ... +80 °C (-40 ... +176 °F)
Measurement environment	For air, nitrogen, hydrogen, argon, helium, and oxygen ¹⁾
IP rating for probe body	IP66: Dust-tight. Protected from powerful water jets from any direction.

1) Consult Vaisala if other chemicals are present. Consider safety regulations with flammable gases.

Table 8 DMP5 inputs and outputs

Property	Description/Value
Operating voltage	15 ... 30 V DC
Current consumption	10 mA typical, 500 mA max.
Digital output	RS-485, non-isolated
Protocols	Modbus RTU

Table 9 DMP5 mechanical specifications

Property	Description/Value
Connector	M12 5-pin A-coded male
Weight	436 g (15.37 oz)
Probe cable length	2 m (6.56 ft) or 10 m (32.8 ft)
Materials	
Probe	AISI 316L
Probe body	AISI 316L
Cable jacket	FEP

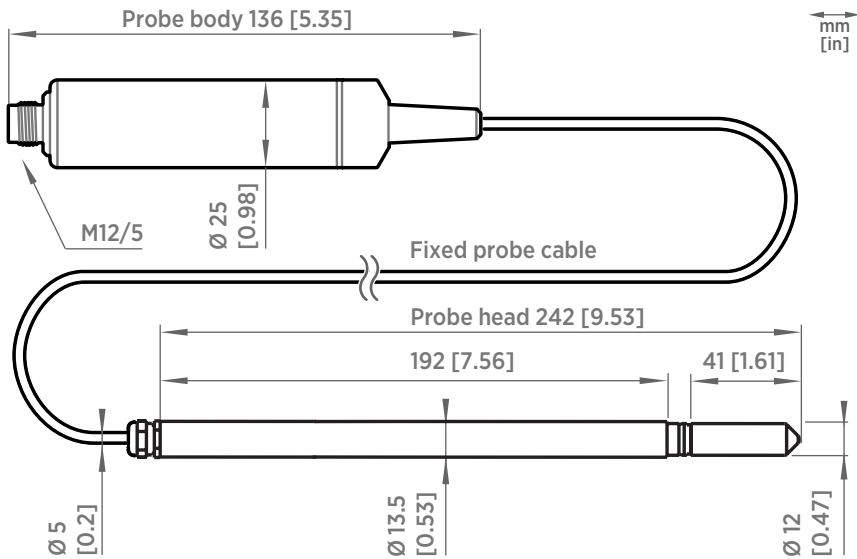

Figure 29 DMP5 dimensions

10.2 DMP6 specifications

Table 10 DMP6 measurement performance

Property	Description/Value
Dew point	
Sensor	DRYCAP® 180S

Property	Description/Value
Measurement range	-25 ... +100 °C (-13 ... +212 °F) T _{d/f}
Accuracy	±2 °C (±3.6 °F) T _{d/f}
Response time 63 % [90 %]:	
From dry to wet	5 s [10 s]
From wet to dry	45 s [5 min]
Mixing ratio	
Measurement range (typical)	0 ... 1000 g/kg (0 ... 7000 gr/lbs)
Accuracy (typical)	±12 % of reading

Table 11 DMP6 operating environment

Property	Description/Value
Operating temperature range of probe head ^{1) 2)}	+100 ... +350 °C (+212 ... +662 °F)
Operating temperature range of probe body	-40 ... +80 °C (-40 ... +176 °F)
Storage temperature	-40 ... +80 °C (-40 ... +176 °F)
Measurement environment	For air, nitrogen, hydrogen, argon, helium, and oxygen ³⁾
IP rating	IP66: Dust-tight. Protected from powerful water jets from any direction.

- 1) *Installation of cooling fins on the cooling set affects the operating temperature range. See the operating range graph.*
- 2) *The operating range specifications apply in stand-still air. High flow rates in the process may reduce the probe performance and cause damage to the equipment.*
- 3) *Consult Vaisala if other chemicals are present. Consider safety regulations with flammable gases.*

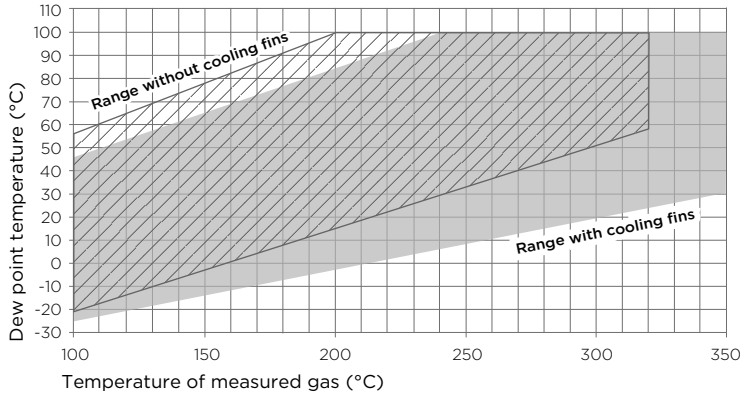

Figure 30 Operating range of DMP6 probe head

Table 12 DMP6 inputs and outputs

Property	Description/Value
Operating voltage	15 ... 30 V DC
Current consumption	10 mA typical, 500 mA max.
Digital output	RS-485, non-isolated
Protocols	Modbus RTU

Table 13 DMP6 mechanical specifications

Property	Description/Value
Connector	M12 5-pin A-coded male
Probe weight	500 g (1.10 lb)
Cooling set weight	3.50 kg (7.72 lb)
Probe cable length	2 m (6.56 ft)
Materials	
Probe	AISI 316L
Probe body	AISI 316L
Cable jacket	FEP
Cooling set	Stainless steel and aluminum

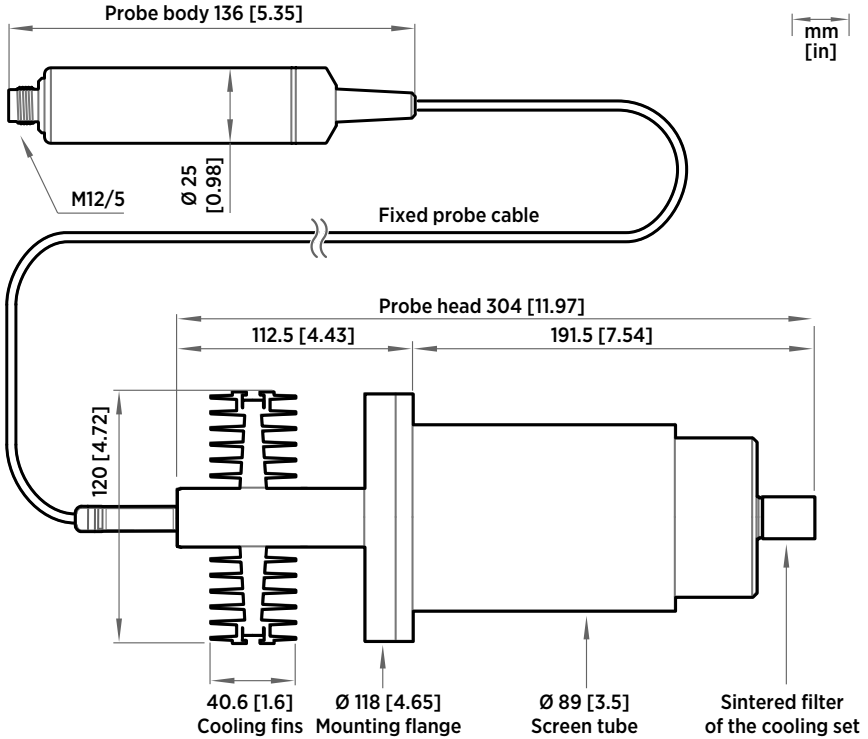

Figure 31 DMP6 dimensions with Cooling Set DMP246CS

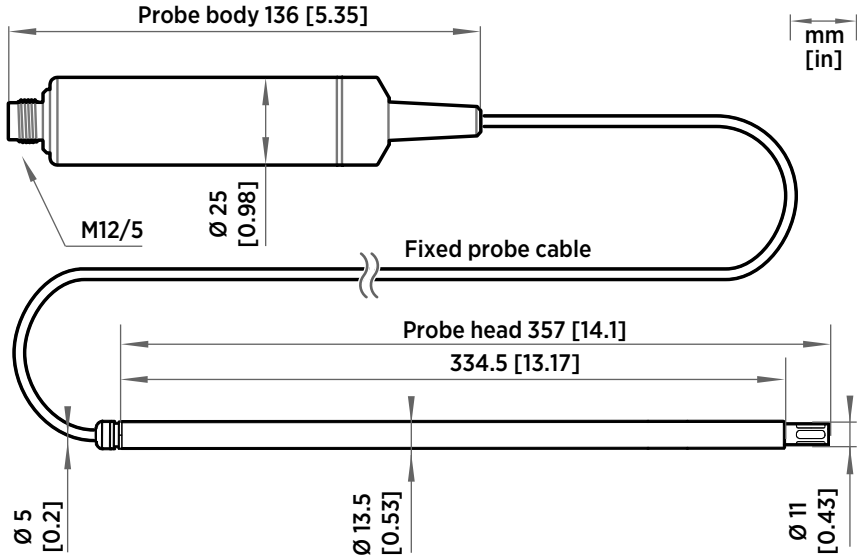

Figure 32 DMP6 probe dimensions

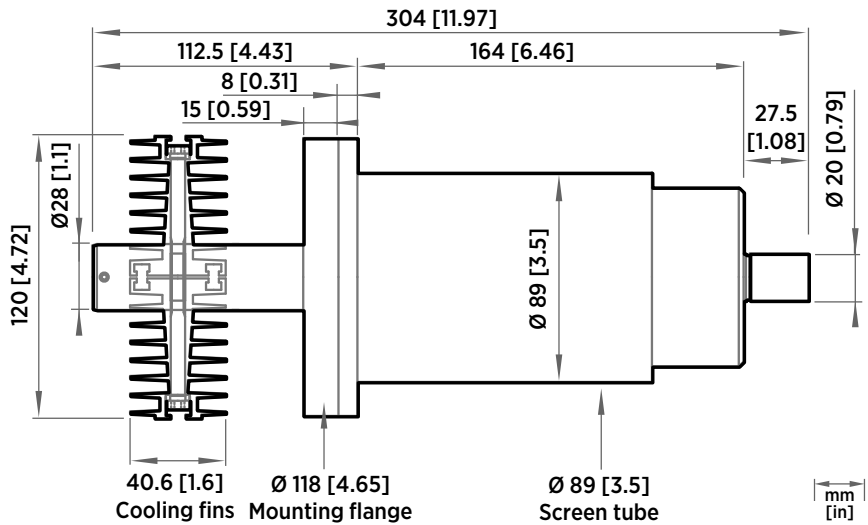

Figure 33 Cooling Set DMP246CS dimensions

10.3 DMP7 specifications

Table 14 DMP7 measurement performance

Property	Description/Value
Dew point	
Sensor	DRYCAP® 180M
Measurement range	-70 ... +80 °C (-94 ... +176 °F) T _{d/f}
Measurement range for continuous use	-70 ... +45 °C (-94 ... +113 °F) T _{d/f}
Accuracy	Up to ±2 °C (±3.6 °F) T _{d/f} See accuracy graph
Response time 63 % [90 %] ¹⁾	
From dry to wet	5 s [15 s]
From wet to dry	45 s [8 min]
Temperature	
Measurement range	0 ... +80 °C (+32 ... +176 °F)
Accuracy	±0.2 °C at room temperature
Temperature sensor	Pt100 RTD Class F0.1 IEC 60751
Relative humidity	
Measurement range	0 ... 70 %RH
Accuracy (RH <10 %RH, at + 20 °C)	±0.004 %RH + 20% of reading
Concentration by volume (ppm)	
Measurement range (typical)	10 ... 2500 ppm
Accuracy (at + 20 °C, 1 bar)	1 ppm + 20% of reading

1) Tested with sintered filter.

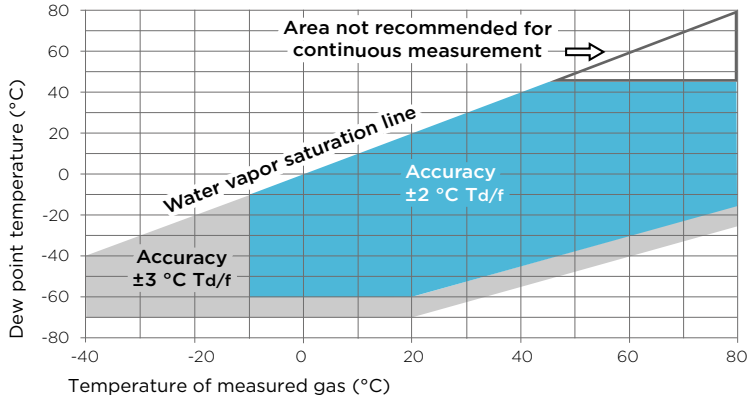

Figure 34 DMP7 dew point accuracy vs. measurement conditions

Table 15 DMP7 operating environment

Property	Description/Value
Operating temperature for probe head	-40 ... +80 °C (-40 ... +176 °F)
Operating temperature for probe body	-40 ... +80 °C (-40 ... +176 °F)
Storage temperature	-40 ... +80 °C (-40 ... +176 °F)
Operating pressure for probe head	0 ... 10 bar (0 ... 145 psia)
Measurement environment	For air, nitrogen, hydrogen, argon, helium, oxygen ¹⁾ , and vacuum
IP rating for probe body	IP66: Dust-tight. Protected from powerful water jets from any direction.
Mechanical durability of probe head	Up to +180 °C (+356 °F) Up to 10 bar/145 psia

1) Consult Vaisala if other chemicals are present. Consider safety regulations with flammable gases.

Table 16 DMP7 inputs and outputs

Property	Description/Value
Operating voltage	15 ... 30 V DC
Current consumption	10 mA typical, 500 mA max.
Digital output	RS-485, non-isolated
Protocols	Modbus RTU

Table 17 DMP7 mechanical specifications

Property	Description/Value
Connector	M12 5-pin A-coded male
Weight	310 g (10.9 oz) with 2 m (6.56 ft) cable
Probe cable length	2 m (6.56 ft) or 10 m (32.80 ft)
Materials	
Probe	AISI 316L
Probe body	AISI 316L
Cable jacket	FEP

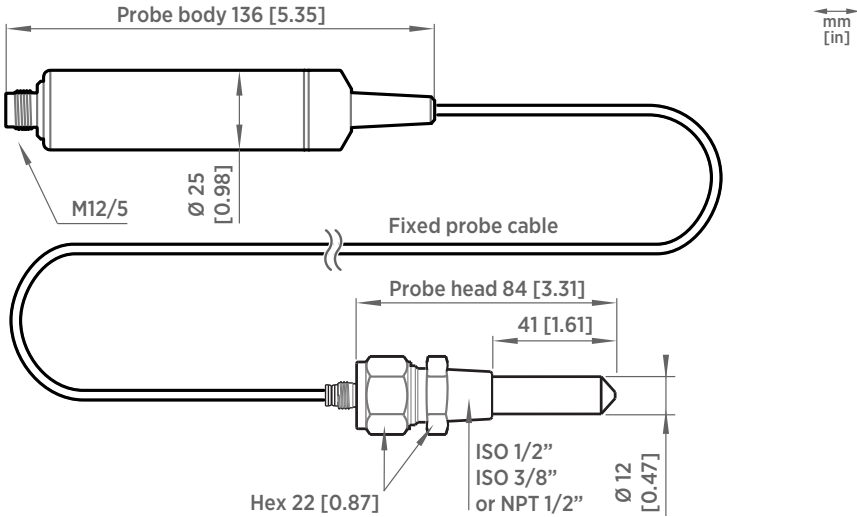

Figure 35 DMP7 dimensions

10.4 DMP8 specifications

Table 18 DMP8 measurement performance

Property	Description/Value
Dew point	
Sensor	DRYCAP® 180M
Measurement range	-70 ... +80 °C (-94 ... +176 °F) T _{d/f}

Property	Description/Value
Measurement range for continuous use	-70 ... +45 °C (-94 ... +113 °F) T _{d/f}
Accuracy up to 20 bar/290 psia	±2 °C/±3.6 °F T _{d/f} See accuracy graph
Accuracy, 20 ... 40 bar/290 ... 580 psia	Additional inaccuracy +1 °C T _{d/f}
Response time 63 % [90 %] ¹⁾ :	
From dry to wet	5 s [15 s]
From wet to dry	45 s [8 min]
Temperature	
Measurement range	0 ... +80 °C (+32 ... +176 °F)
Accuracy	±0.2 °C at room temperature
Temperature sensor	Pt100 RTD Class F0.1 IEC 60751
Relative humidity	
Measurement range	0 ... 70 %RH
Accuracy (RH <10 %RH, at + 20 °C)	±0.004 %RH + 20% of reading
Concentration by volume (ppm)	
Measurement range (typical)	10 ... 2500 ppm
Accuracy (at + 20 °C, 1 bar)	1 ppm + 20% of reading

1) Tested with sintered filter.

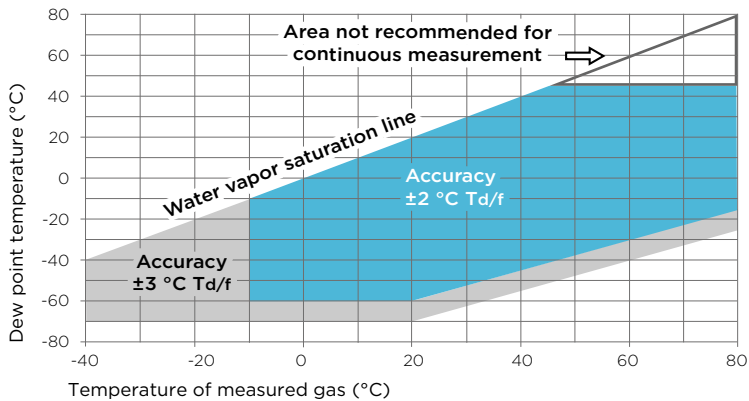

Figure 36 DMP8 dew point accuracy vs. measurement conditions

Table 19 DMP8 operating environment

Property	Description/Value
Operating temperature for probe head	-40 ... +80 °C (-40 ... +176 °F)
Operating temperature for probe body	-40 ... +80 °C (-40 ... +176 °F)
Storage temperature	-40 ... +80 °C (-40 ... +176 °F)
Operating pressure for probe head	0 ... 40 bar (0 ... 580 psia)
Measurement environment	For air, nitrogen, hydrogen, argon, helium, oxygen ¹⁾ , and vacuum
IP rating for probe body	IP66: Dust-tight. Protected from powerful water jets from any direction.
Mechanical durability of probe head	Up to +180 °C (+356 °F) Up to 70 bar/1015 psia

1) Consult Vaisala if other chemicals are present. Consider safety regulations with flammable gases.

Table 20 DMP8 inputs and outputs

Property	Description/Value
Operating voltage	15 ... 30 V DC
Current consumption	10 mA typical, 500 mA max.
Digital output	RS-485, non-isolated
Protocols	Modbus RTU

Table 21 DMP8 mechanical specifications

Property	Description/Value
Connector	M12 5-pin A-coded male
Weight	512 g (18.1 oz)
Probe cable length	2 m (6.56 ft)
Materials	
Probe	AISI 316L
Probe body	AISI 316L
Cable jacket	FEP

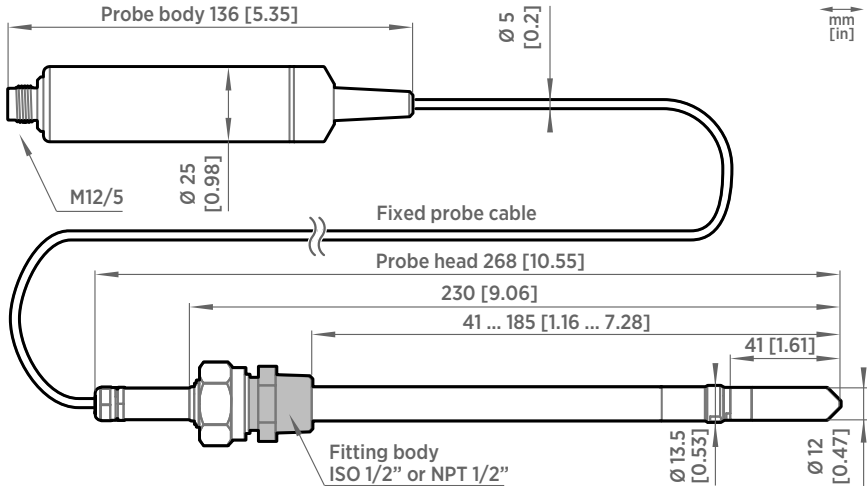

Figure 37 DMP8 dimensions

10.5 Accessories and spare parts



Information on spare parts, accessories, and calibration products is available online at www.vaisala.com and store.vaisala.com.

Connection cables

Table 22 Connection cables

Description	Item code
Connection cable, M12-5F - M12-5M, 1 m	INDIGOCABLE1M
Connection cable, M12-5F - M12-5M, 3 m	INDIGOCABLE3M
Connection cable, M12-5F - M12-5M, 5 m	INDIGOCABLE5M
Connection cable, M12-5F - M12-5M, 10 m	INDIGOCABLE10M
Connection cable, M12-5F - open wires, 0.3 m	CBL210896-03MSP
Connection cable, M12-5F - open wires, 1 m	CBL210896-1MSP
Connection cable, M12-5F - open wires, 3 m	CBL210896-3MSP
Connection cable, M12-5F - open wires, 5 m	CBL210896-5MSP
Connection cable, M12-5F - open wires, 10 m	CBL210896-10MSP

Description	Item code
Connection cable, M12-5F - open wires, 1.5 m	223263SP
Connection cable, M12-5F - open wires, 10 m	216546SP
Connection cable, M12-5F 90° - open wires, 0.6 m	244669SP
Flat cable, M12-5F - M12-5M, 1 m	CBL210493SP
Connection cable for Indigo80, M12-5F - M12-5M, 1.5 m	272075SP
Vaisala Indigo USB adapter ¹⁾	USB2

1) *Vaisala Insight software for Windows available at www.vaisala.com/insight*

DMP5

Table 23 DMP5 accessories

Description	Vaisala item code
Mounting flange	210696

Table 24 DMP5 spare parts

Description	Vaisala item code
Sintered stainless steel filter	HM47280SP

DMP6

Table 25 DMP6 accessories

Description	Vaisala item code
Cooling set	DMP246CS

Table 26 DMP6 spare parts

Description	Vaisala item code
Sintered stainless steel filter (Ø 20 mm) for cooling set	HM46780
Plug D13.5 mm with wire rope	217738
Installation flange for cooling set	217490

DMP7

Table 27 DMP7 accessories

Description	Vaisala item code
Swagelok ISO 3/8"	SWG12ISO38
Swagelok ISO 1/2"	SWG12ISO12
Swagelok NPT 1/2"	SWG12NPT12
Magnetic probe holder for Ø 12 mm probe heads 1)	ASM213382SP

1) Not suitable for use at extreme temperatures.

Table 28 DMP7 spare parts

Description	Vaisala item code
Sintered stainless steel filter	HM47280
Stainless steel filter for vacuum	HM47453

DMP8

Table 29 DMP8 accessories

Description	Vaisala item code
Fitting body ISO R 1/2" with leak screw	ISOFITBODASP
Fitting body ISO R 1/2" (no leak screw)	DRW212076SP
Fitting body NPT 1/2" (no leak screw)	NPTFITBODASP
Sampling cell	DMT242SC
Sampling cell with Swagelok connectors	DMT242SC2
Ball valve kit ISO 1/2" with welding joint	BALLVALVE-1
Duct installation flange for ISO R 1/2" thread	DM240FASP
Thread adapter ISO 1/2" to NPT 1/2"	210662SP
Blind plug ISO 1/2"	218773

Table 30 DMP8 spare parts

Description	Vaisala item code
Sintered stainless steel filter	HM47280SP

Description	Vaisala item code
Stainless steel filter for vacuum	HM47453SP
Manual pressing handle	HM36854SP

Appendix A. Modbus reference

A.1 Default communication settings

Table 31 Default Modbus serial communication settings

Property	Description/Value
Serial bit rate	19200
Parity	None
Number of data bits	8
Number of stop bits	2
Flow control	None
Modbus device address	240

You can use up to ten probes on the same RS-485 line. You must configure each probe on the line to have a different Modbus address.

A.2 Function codes

Table 32 Modbus function codes

Function code (decimal)	Function code (hexadecimal)	Name	Notes
03	03 _{hex}	Read Holding Registers	Class 0
16	10 _{hex}	Write Multiple Registers	Class 0
43 / 14	2B _{hex} / 0E _{hex}	Read Device Identification	

A.3 Data encoding

In the data registers, the numeric values are available in one or two formats with separate register addresses: 32-bit IEEE floating point format and/or 16-bit signed integer format.



For values that have both 32-bit and 16-bit register available, use of the 32-bit register is recommended. Some values may exceed the signed 16-bit range even in normal operation.

A.3.1 32-bit floating point or 32-bit integer format

Registers using **32-bit float** data format are encoded using the **binary32** encoding defined in IEEE 754. The format is also known as "single-precision floating point format".

The least significant 16 bits of a floating point number are placed at the Modbus register listed in the table, while the most significant 16 bits are placed in the register with number/address + 1, as specified in Open Modbus TCP Specification, Release 1.0. This is also known as "little-endian" or "Modicon" word order.

Despite the specification, some Modbus masters may expect a "big-endian" word order (most significant word first). In such case, you must select "word-swapped" floating point format in your Modbus master for the Modbus registers of the device.

A complete 32-bit floating point or 32-bit integer value should be read and written in a single Modbus transaction.



CAUTION! Reading the measurement data registers with incorrect floating point format setting may occasionally result in correct-looking, but nevertheless incorrect values.



It is highly recommended to verify that you have configured the floating point format correctly on your Modbus host system by reading a floating point value from a test value register.

A.3.2 16-bit integer format

Some 16-bit integer values in the data registers are scaled to include the necessary decimals. The scaling factors for those values are shown in the register tables.

Table 33 Interpretation of 16-bit signed integer values

Value (decimal)	Value (hexadecimal)	Description
0 ... 32766	0000 _{hex} ... 7FFE _{hex}	Value in range 0 ... 32766
32767	7FFF _{hex}	Value is 32767 or larger
32768	8000 _{hex}	Value is not available
32769	8001 _{hex}	Value is -32767 or smaller
32770 ... 65535	8002 _{hex} ... FFFF _{hex}	Value in range -32766 ... -1 (2's complement)

A.4 Modbus registers

Registers are numbered in decimal, starting from 1. Register addresses in actual Modbus messages (Modbus Protocol Data Unit (PDU)) are in hexadecimal and start from zero. Register number 1 corresponds to address 0_{hex} in the actual Modbus message.



CAUTION! Reading the wrong register(s) may result in correct-looking values. Check the reference documentation of your Modbus host (PLC) to verify which notation it uses for Modbus register addresses.

A.4.1 Measurement data registers

Table 34 Floating point measurement data registers (read-only)

Register number	Address	Description	Data format	Unit
1	0000 _{hex}	Relative humidity	32-bit float	%RH
3	0002 _{hex}	Temperature	32-bit float	°C
7	0006 _{hex}	Dew point temperature	32-bit float	°C
9	0008 _{hex}	Dew/frost point temperature	32-bit float	°C
11	000A _{hex}	Dew/frost point temperature at 1 atm	32-bit float	°C
13	000C _{hex}	Dew point temperature at 1 atm	32-bit float	°C
15	000E _{hex}	Absolute humidity	32-bit float	g/m ³
17	0010 _{hex}	Mixing ratio	32-bit float	g/kg
21	0014 _{hex}	Water concentration	32-bit float	ppm _v
23	0016 _{hex}	Water vapor pressure	32-bit float	hPa
25	0018 _{hex}	Water vapor saturation pressure	32-bit float	hPa
27	001A _{hex}	Enthalpy	32-bit float	kJ/kg
31	001E _{hex}	Dew point temperature difference	32-bit float	°C
33	0020 _{hex}	Absolute humidity at NTP	32-bit float	g/m ³
65	0040 _{hex}	Water mass fraction	32-bit float	ppm _w

Table 35 Integer measurement data registers (read-only)

Register number	Address	Description	Data format	Scale factor	Offset	Unit
257	0100 _{hex}	Relative humidity	16-bit signed integer	100	0	%RH
258	0101 _{hex}	Temperature	16-bit signed integer	100	0	°C
260	0103 _{hex}	Dew point temperature	16-bit signed integer	100	0	°C
261	0104 _{hex}	Dew/frost point temperature	16-bit signed integer	100	0	°C
262	0105 _{hex}	Dew/frost point temperature at 1 atm	16-bit signed integer	100	0	°C
263	0106 _{hex}	Dew point temperature at 1 atm	16-bit signed integer	100	0	°C
264	0107 _{hex}	Absolute humidity	16-bit signed integer	100	0	g/m ³
265	0108 _{hex}	Mixing ratio	16-bit signed integer	100	0	g/kg
267	010A _{hex}	Water concentration	16-bit signed integer	1	0	ppm _v
268	010B _{hex}	Water vapor pressure	16-bit signed integer	10	0	hPa
269	010C _{hex}	Water vapor saturation pressure	16-bit signed integer	10	0	hPa
270	010D _{hex}	Enthalpy	16-bit signed integer	100	0	kJ/kg
272	010F _{hex}	Dew point temperature difference	16-bit signed integer	10	0	°C
273	0110 _{hex}	Absolute humidity at NTP	16-bit signed integer	100	0	g/m ³
289	0120 _{hex}	Water mass fraction	16-bit signed integer	1	0	ppm _w

A.4.2 Diagnostic data registers

Table 36 Floating point diagnostic data registers (read-only)

Register number	Address	Description	Data format	Unit
37	0024 _{hex}	Sensor saturation ratio	32-bit float	%
39	0026 _{hex}	Sensor temperature	32-bit float	°C

Table 37 Integer diagnostic data registers (read-only)

Register number	Address	Register description	Data format	Scale factor	Offset	Unit
275	0112 _{hex}	Sensor saturation ratio	16-bit signed integer	100	0	%
276	0113 _{hex}	Sensor temperature	16-bit signed integer	100	0	°C

A.4.3 Configuration registers

Table 38 Modbus configuration data registers (writable)

Register number	Address	Description	Data format	Unit / Valid range
Compensation setpoints				
769	0300 _{hex}	Pressure compensation setpoint	32-bit float	Unit: hPa Default: 1013.25 hPa
821	0334 _{hex}	Temperature compensation setpoint. If a value is written to this register, probe uses it instead of its own temperature measurement.	32-bit float	Unit: °C
General				
2561	0A00 _{hex}	Device tag	Text	Text string of 24 bytes in UTF-8 encoding
Sensor purge				
773	0304 _{hex}	Sensor purge interval	32-bit float	Unit: min 10 ... 14400

Sensor purge				
1283	0502 _{hex}	Interval purge on/off	16-bit boolean	0 = Off 1 = On
1284	0503 _{hex}	Startup purge on/off	16-bit boolean	0 = Off 1 = On
Filtering				
795	031A _{hex}	Measurement filtering factor	32-bit float	Range: 0.000 ... 1.000 1.000 = Reading shows 100% of the most recent measured value (no filtering, default) 0.01 ... 0.99 = Reading shows 1 ... 99% of the most recent measured value and part of the previous reading (filtering is applied). For example, "0.9" means that the filtered measurement reading = 90% of the most recent measured value + 10% of the previous reading.
1282	0501 _{hex}	Enable or disable measurement filtering using the user-defined filtering factor (register 031A _{hex})	16-bit boolean	0 = Off 1 = On
Communication				
1537	0600 _{hex}	Modbus address	16-bit integer	1 ... 247 Default: 240

Communication				
1538	0601 _{hex}	Bit rate	enum	0 = 300 1 = 600 2 = 1200 3 = 2400 4 = 4800 5 = 9600 6 = 19200 7 = 38400 8 = 57600 9 = 115200
1539	0602 _{hex}	Parity, data, stop bits	enum	0 = None, 8, 1 1 = None, 8, 2 2 = Even, 8, 1 3 = Even, 8, 2 4 = Odd, 8, 1 5 = Odd, 8, 2 (default: 1 = None, 8, 2)
1540	0603 _{hex}	Response delay	16-bit integer	Unit: ms Range: 0 ... 1000
Functions				
1285	0504 _{hex}	Start sensor purge	16-bit function status	When writing to register: 1 = Start purge
1542	0605 _{hex}	Restart device	16-bit function status	When writing to register: 1 = Restart the device

A.4.4 Status registers

Table 39 Modbus status data registers (read-only)

Register number	Address	Description	Data format	Note
513	0200 _{hex}	Error status	16-bit boolean	0000 _{hex} : One or more errors active 0001 _{hex} : No errors

Register number	Address	Description	Data format	Note
514	0201 _{hex}	Online status	16-bit boolean	0000_{hex} : Output locked 0001_{hex} : Online data available
516	0203 _{hex}	Error code	32-bit signed integer	See Table 40 (page 82) .
518	0205 _{hex}	Security hash	32-bit signed integer	Security hash changes when any change is made to device settings or adjustments.
520	0207 _{hex}	RH measurement status	16-bit signed integer	0000_{hex} : Status OK 0001_{hex} : Measurement is not available
521	0208 _{hex}	T measurement status	16-bit signed integer	0002_{hex} : Measurement is not reliable
522	0209 _{hex}	T _{d/f} measurement status	16-bit signed integer	0004_{hex} : Under range 0008_{hex} : Over range 0020_{hex} : Value locked 0080_{hex} : Sensor failure 0100_{hex} : Measurement is not ready
523	020A _{hex}	Device status	16-bit signed integer	0000_{hex} : Status OK 0001_{hex} : Critical error, maintenance needed 0002_{hex} : Error, device may recover automatically 0004_{hex} : Warning 0008_{hex} : Notification 0010_{hex} : Calibration mode active

Table 40 Error codes in register 0203_{hex}

Bitmask	Error message	Severity
0000 _{hex}	Status OK	
0001 _{hex}	Temperature measurement error	Error
0002 _{hex}	Humidity measurement error	Error

Bitmask	Error message	Severity
0004 _{hex}	Humidity sensor failure	Error
0008 _{hex}	Capacitance reference error	Error
0010 _{hex}	Ambient temperature out of range	Error
800000 _{hex}	Sensor heater failure	Warning

A.4.5 Test value registers

Read the known test values from the test registers to verify the functionality of your Modbus implementation.

Table 41 Modbus test registers (read-only)

Register number	Address	Description	Data format	Test value
7937	1F00 _{hex}	Signed integer	16-bit integer	-12345
7938	1F01 _{hex}	Floating point	32-bit float	-123.45
7940	1F03 _{hex}	Text string	7-character ASCII string	Text string "-123.45"

A.5 Device identification objects

Table 42 Device identification objects

Object ID	Object ID (hexadecimal)	Object name	Example contents
0	00 _{hex}	VendorName	"Vaisala"
1	01 _{hex}	ProductCode	"DMP7"
2	02 _{hex}	MajorMinorVersion	"1.2.3" Software version of the device.
3	03 _{hex}	VendorUrl	" http://www.vaisala.com/ "
4	04 _{hex}	ProductName	"Dew Point and Temperature Probe DMP7"
5	05 _{hex}	ModelName	"7E2A2A0A000" Configuration code of the device. Length and content of the code are model-specific.

Object ID	Object ID (hexadecimal)	Object name	Example contents
6	06 _{hex}	UserApplicationName	User definable information text (see configuration register 0A00 _{hex})
128	80 _{hex}	SerialNumber ¹⁾	"K0710040"
129	81 _{hex}	CalibrationDate ¹⁾	"2020-01-31" Calibration date in YYYY-MM-DD format. Empty string if not set/valid.
130	82 _{hex}	CalibrationText ¹⁾	"Vaisala/HEL" Calibration information text. Empty string if not set/valid.

1) *Vaisala-specific device information.*

A.6 Exception responses

Table 43 Modbus exception responses

Code	Name	Reason
01	ILLEGAL FUNCTION	Unsupported function code
02	ILLEGAL DATA ADDRESS	Register address or Object ID out of valid ranges
03	ILLEGAL DATA VALUE	Otherwise invalid request

Accessing unavailable (temporarily missing) measurement data does not generate a Modbus exception. "Unavailable" value (a quiet NaN for floating point data or 8000_{hex} for integer data) is returned instead. An exception is generated only for any access outside the applicable register ranges.

A.7 Modbus communication examples

Reading dew point temperature value



Device address used in the following examples is 240 (F0_{hex}).
Measurement values returned by the device change depending on ambient conditions and/or device settings.

Request		Response	
Bytes on the line (hexadecimal)	Description	Bytes on the line (hexadecimal)	Description
(silence for 3.5 bytes)	Start of Modbus RTU frame	(silence for 3.5 bytes)	Start of Modbus RTU frame
F0 _{hex}	Probe address	F0 _{hex}	Probe address
03 _{hex}	Function (Read Holding Registers)	03 _{hex}	Function (Read Holding Registers)
00 _{hex}	Register address	04 _{hex}	Number of data bytes
06 _{hex}		FD _{hex}	Value of first register (least significant word)
00 _{hex}	Number of 16-bit registers to read (2)	F9 _{hex}	
02 _{hex}		41 _{hex}	
31 _{hex}	Modbus RTU checksum	72 _{hex}	Modbus RTU checksum
2B _{hex}		4B _{hex}	
(silence for 3.5 bytes)	End of Modbus RTU frame	14 _{hex}	End of Modbus RTU frame
		(silence for 3.5 bytes)	

Communication description	
Register address	7 (1-based Modbus documentation format) = 0006 _{hex} (0-based format used in actual communication).
Data format	Two 16-bit Modbus registers interpreted as IEEE 754 binary32 floating point value, least significant word first.
Returned value	4172FDF9 _{hex} , which is binary32 representation of 15.187 (°C T _d).

Writing pressure compensation value

Request		Response	
Bytes on the line (hexadecimal)	Description	Bytes on the line (hexadecimal)	Description
(silence for 3.5 bytes)	Start of Modbus RTU frame	(silence for 3.5 bytes)	Start of Modbus RTU frame
F0 _{hex}	Probe address	F0 _{hex}	Probe address
10 _{hex}	Function (Write Multiple Registers)	10 _{hex}	Function (Write Multiple Registers)
03 _{hex}	Register address	03 _{hex}	Register address
00 _{hex}		00 _{hex}	
00 _{hex}	Number of registers to write (2)	00 _{hex}	Number of 16-bit registers written (2)
02 _{hex}		02 _{hex}	
04 _{hex}	Number of data bytes	54 _{hex}	Modbus RTU checksum
6E _{hex}	Value for first register (least significant word)	AD _{hex}	
14 _{hex}		Value for second register (least significant word)	(silence for 3.5 bytes)
44 _{hex}			
75 _{hex}			
4E _{hex}	Modbus RTU checksum	<div style="border: 1px solid gray; padding: 10px; background-color: #f0f0f0;"> <p> The response to a write function informs that the function was correctly received by the device. It does not guarantee that the written value was accepted by the device (for example, in case out-of-range values). To verify that the value was really accepted by the device, read the register value after writing.</p> </div>	
AB _{hex}			
(silence for 3.5 bytes)	End of Modbus RTU frame		

Communication description	
Register address	769 (1-based Modbus documentation format) = 0300 _{hex} (0-based format used in actual communication).

Communication description	
Data format	Two 16-bit Modbus registers interpreted as IEEE 754 binary32 floating point value, least significant word first.
Value to write	44756E14 _{hex} = 981.72 (hPa)

Maintenance and calibration services



Vaisala offers comprehensive customer care throughout the life cycle of our measurement instruments and systems. Our factory services are provided worldwide with fast deliveries. For more information, see www.vaisala.com/calibration.

- Vaisala Online Store at store.vaisala.com is available for most countries. You can browse the offering by product model and order the right accessories, spare parts, or maintenance and calibration services.
- To contact your local maintenance and calibration expert, see www.vaisala.com/contactus.

Warranty

For standard warranty terms and conditions, see www.vaisala.com/warranty.

Please observe that any such warranty may not be valid in case of damage due to normal wear and tear, exceptional operating conditions, negligent handling or installation, or unauthorized modifications. Please see the applicable supply contract or Conditions of Sale for details of the warranty for each product.

Technical support



Contact Vaisala technical support at helpdesk@vaisala.com. Provide at least the following supporting information as applicable:

- Product name, model, and serial number
- Software/Firmware version
- Name and location of the installation site
- Name and contact information of a technical person who can provide further information on the problem

For more information, see www.vaisala.com/support.

Recycling



Recycle all applicable material according to local regulations.

VAISALA

www.vaisala.com

